

Big data in Controlled Environment Agriculture for improving the nutritional factors of the plants

Rares C. Nistor, PhD

MELiSSA Worksop, Rome, 2018

PLNT
GEEK



Hochschule Neubrandenburg
University of Applied Sciences



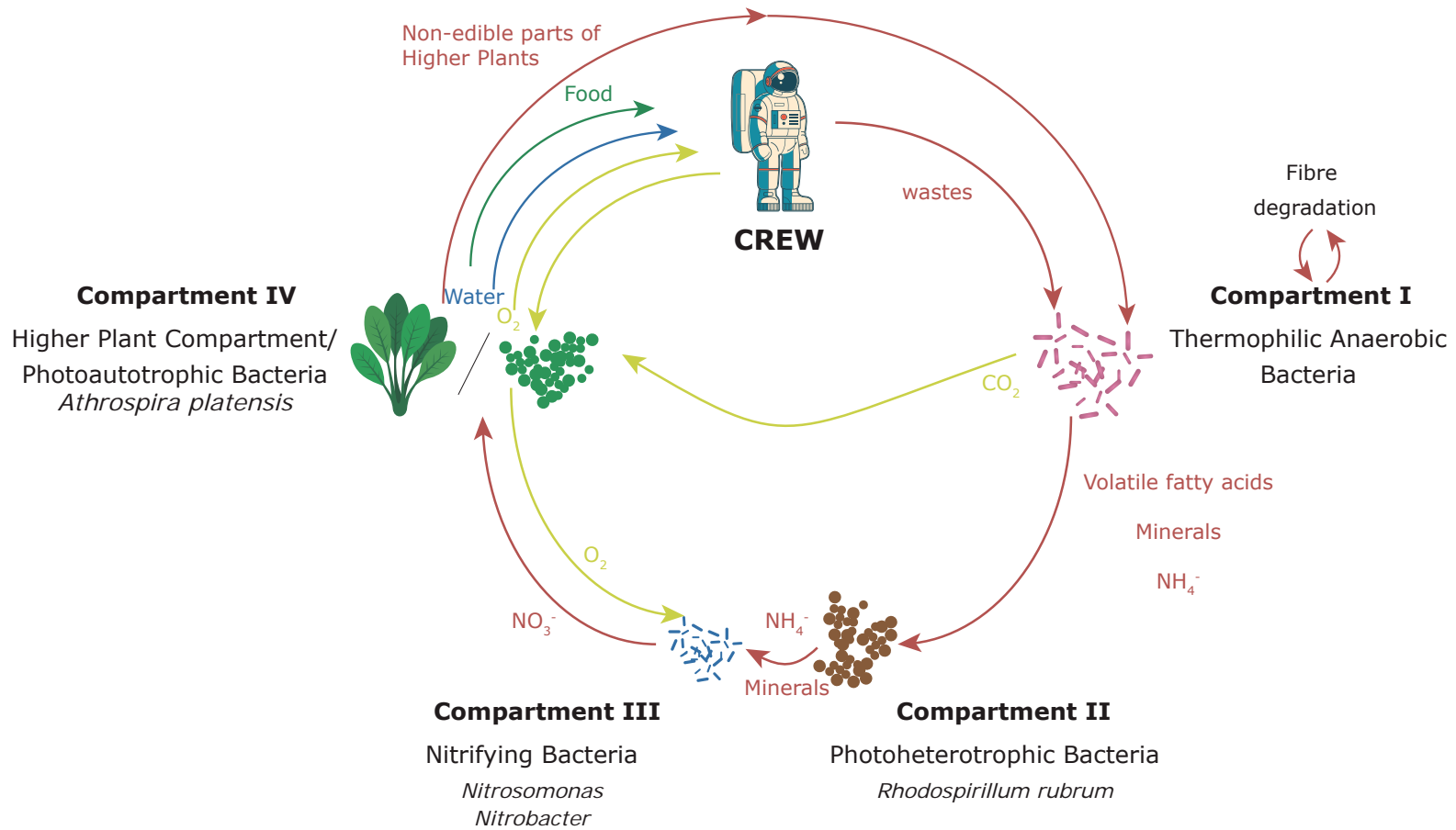

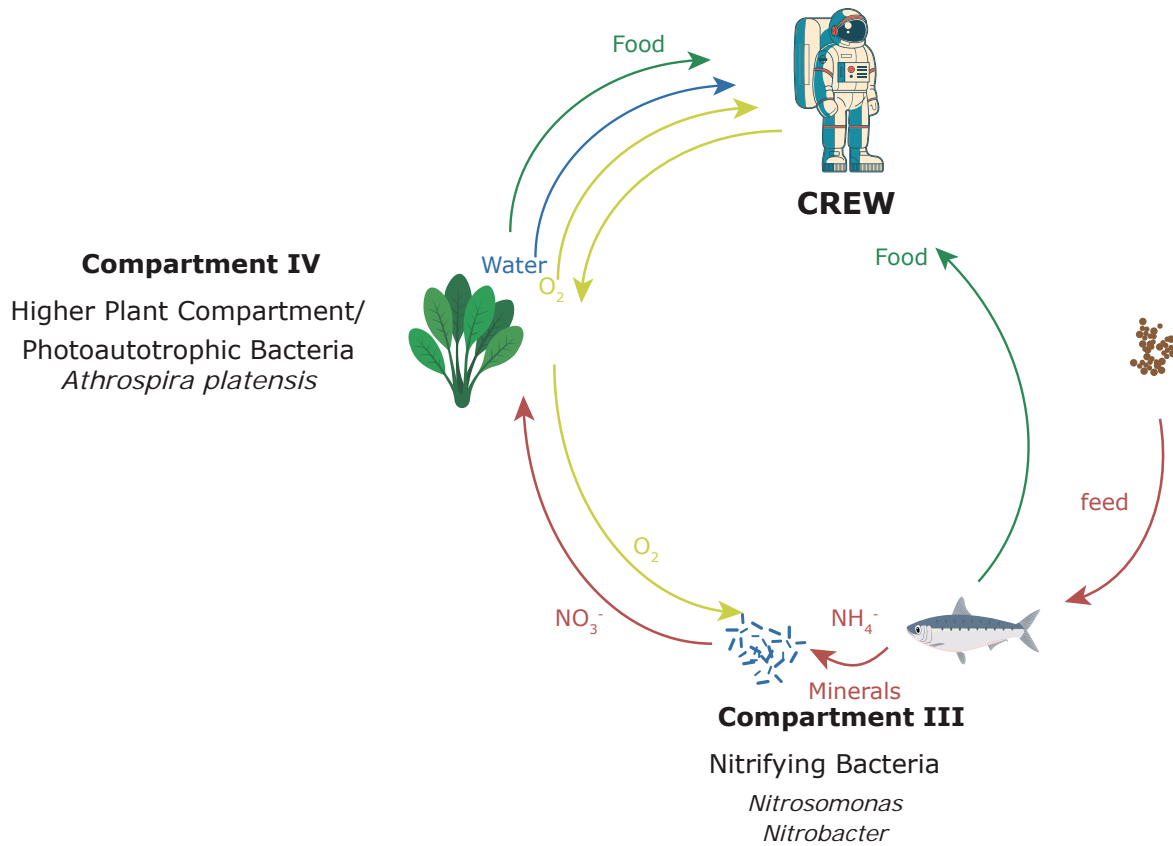



Quantity and Quality of plants

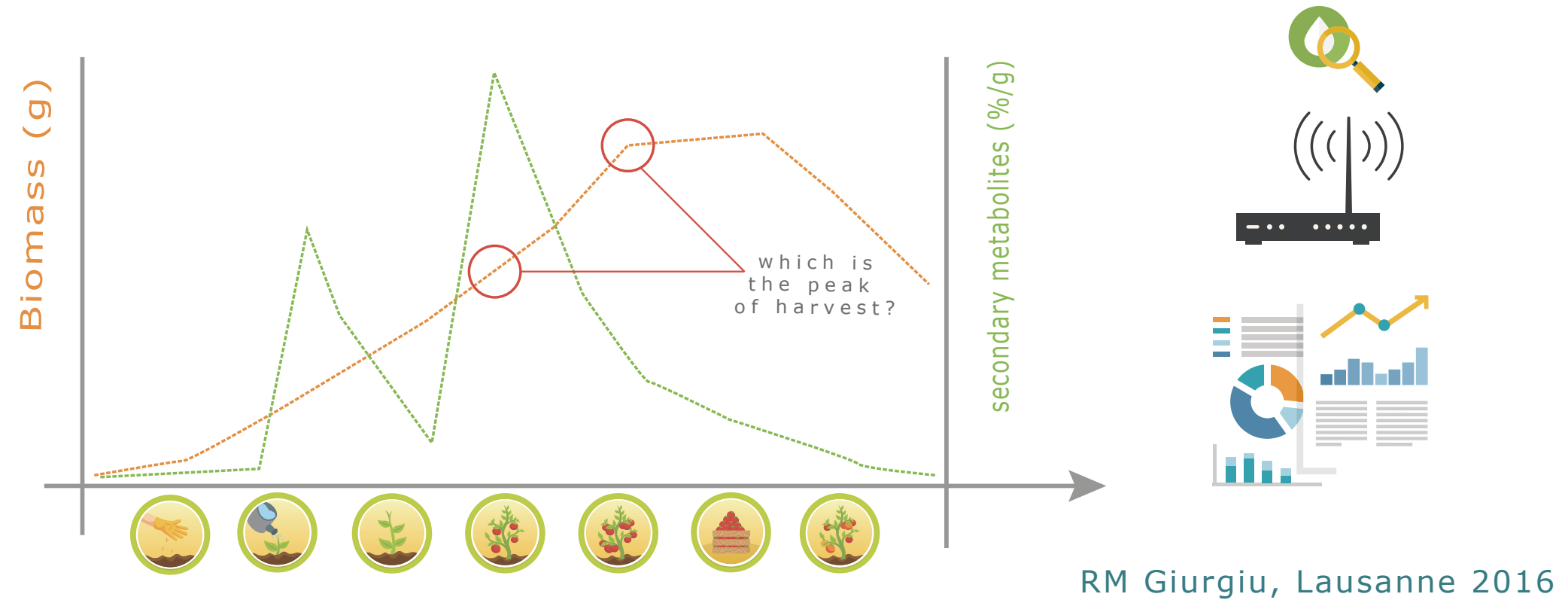



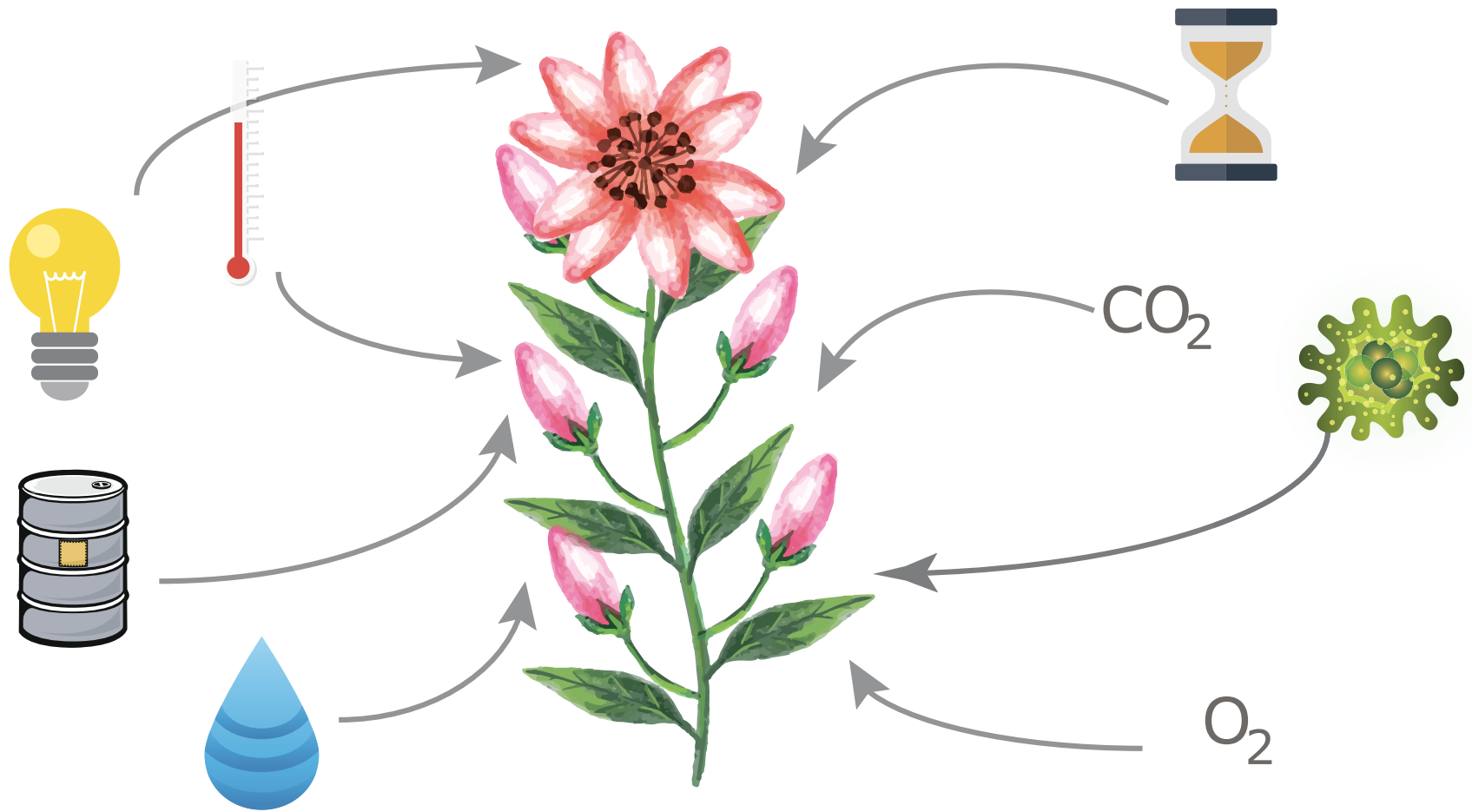

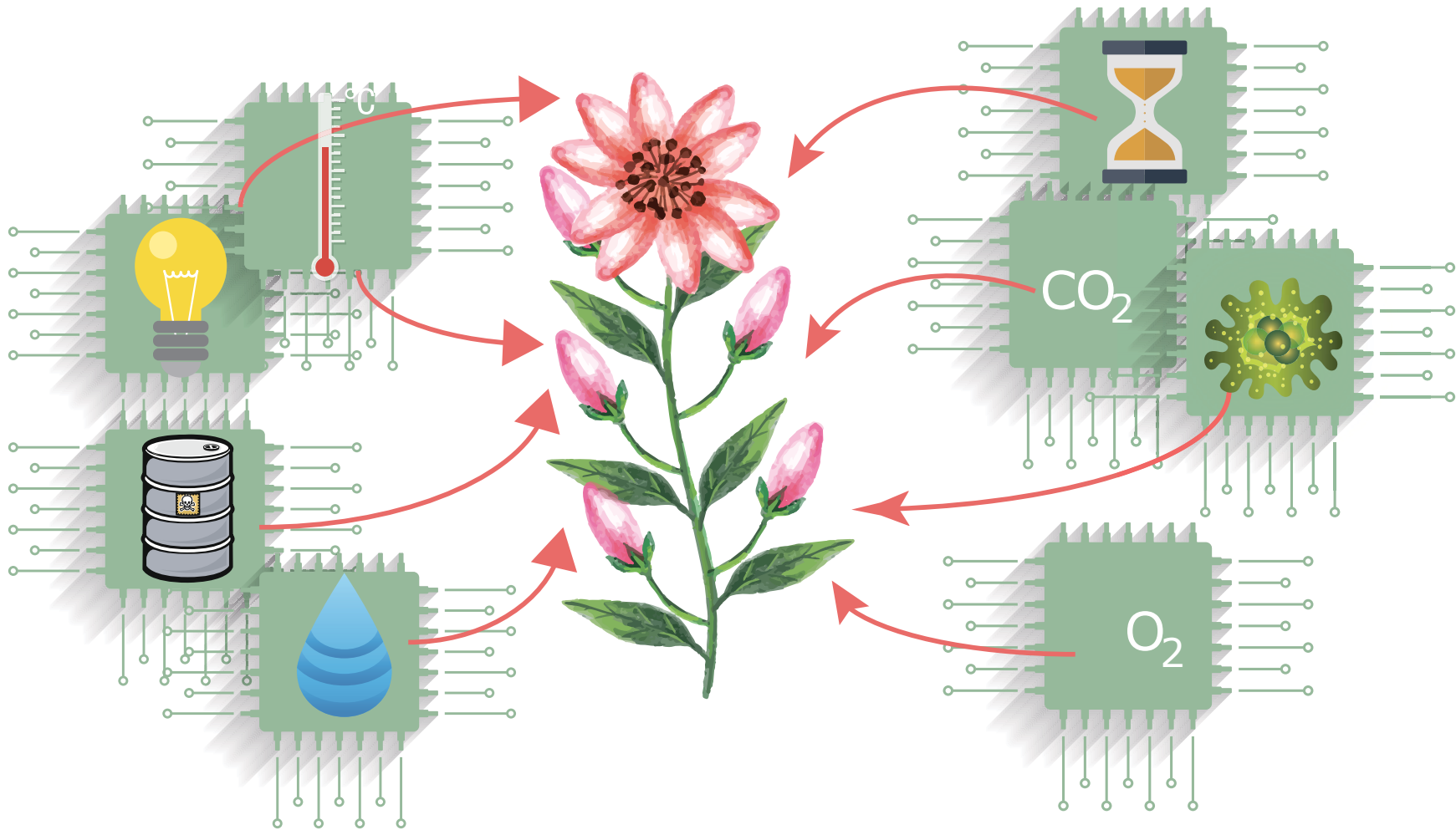



Number of sensors/ price

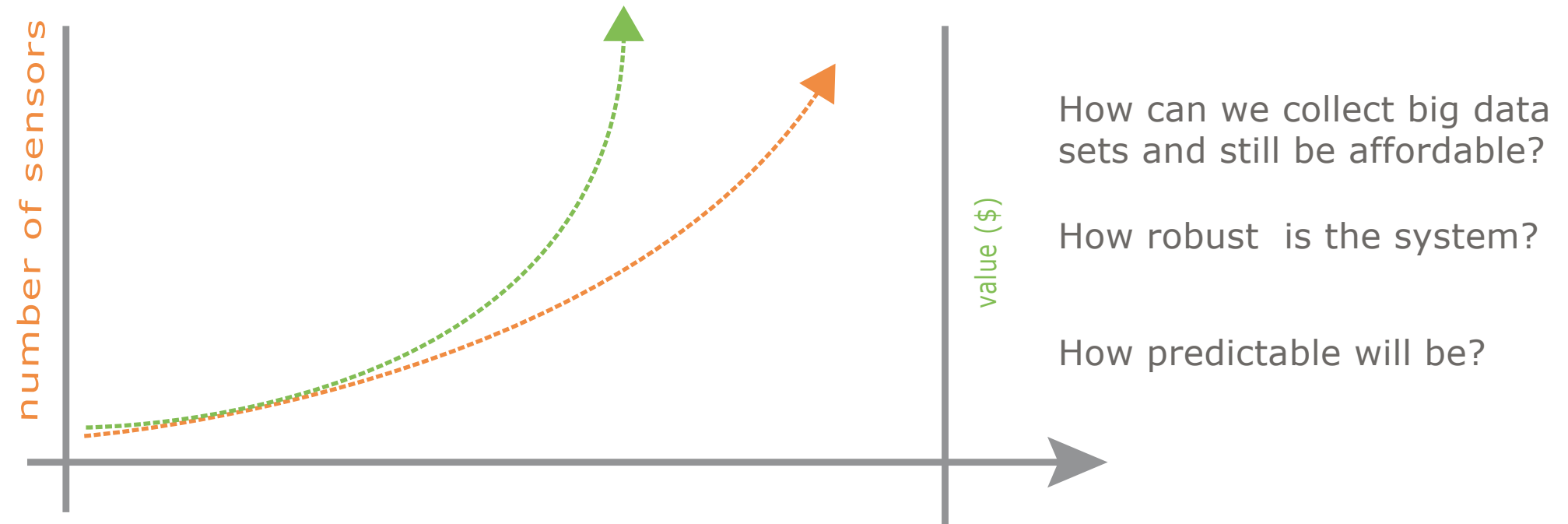

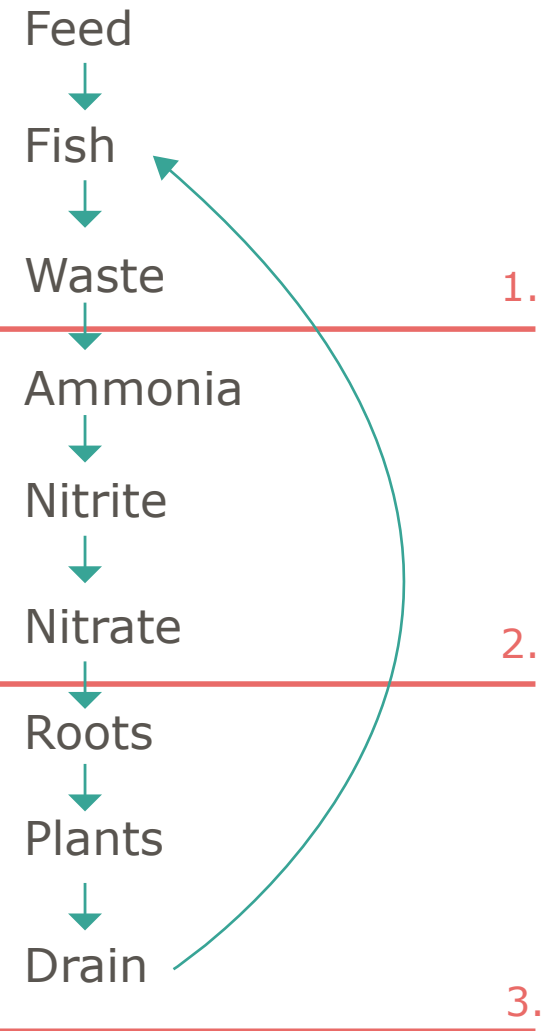
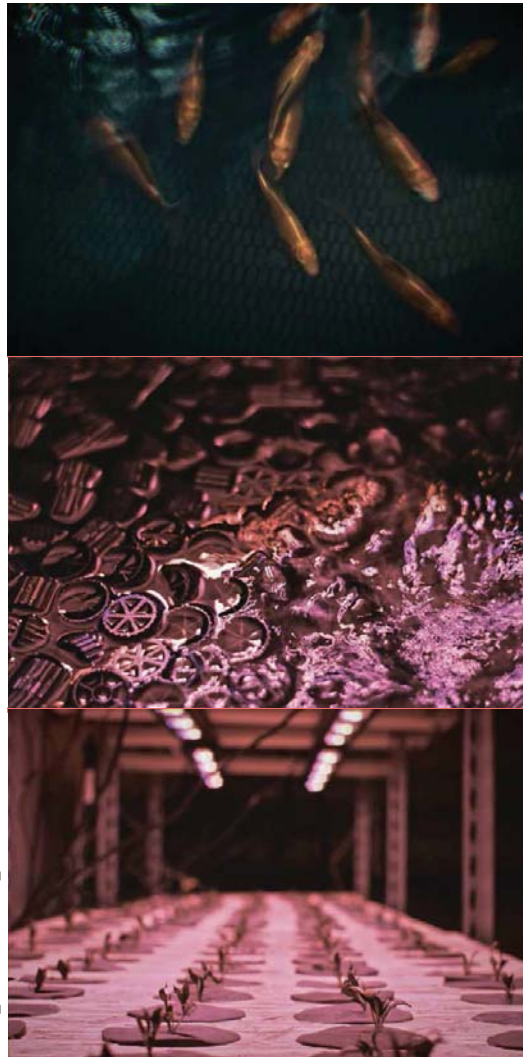
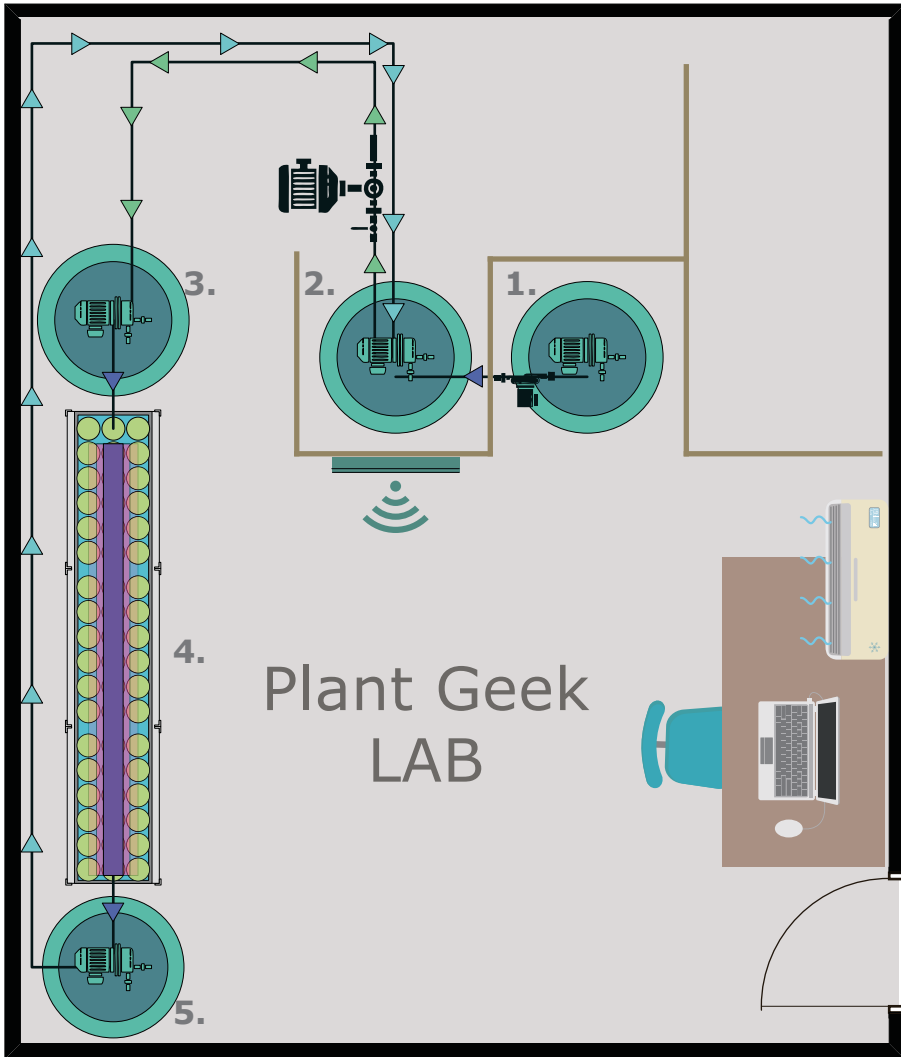



- pH
- electrical conductivity
- nutrient solution temperature
- dissolved oxygen
- PAR
- temperature
- humidity
- IR CAM
- Raspberry Pi
- Arduino

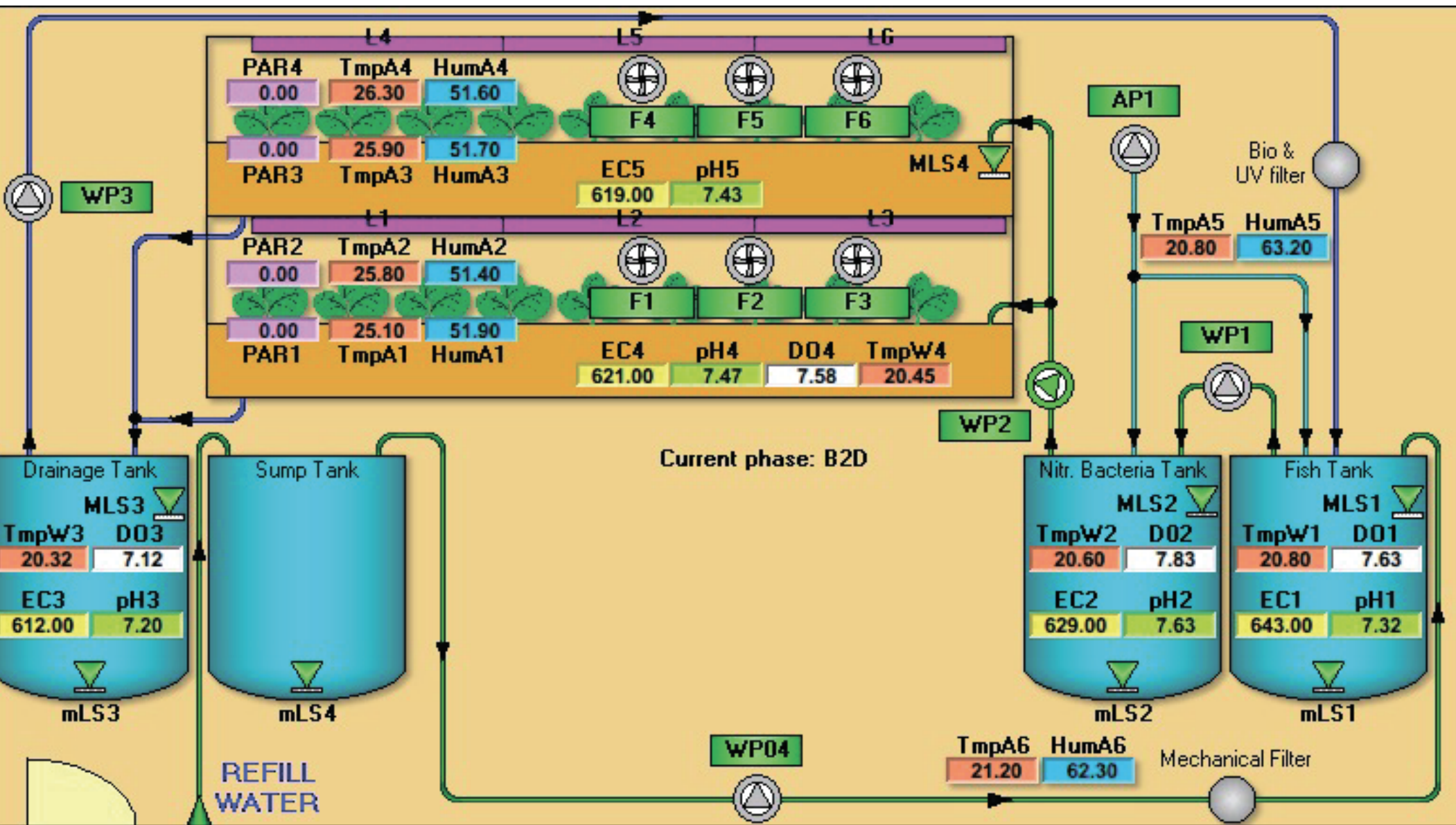



Real time data and monitoring:

☰ Aquaponic System, 09/04/2018 - 11/04/2018

Generated 11/04/2018 22:43:15

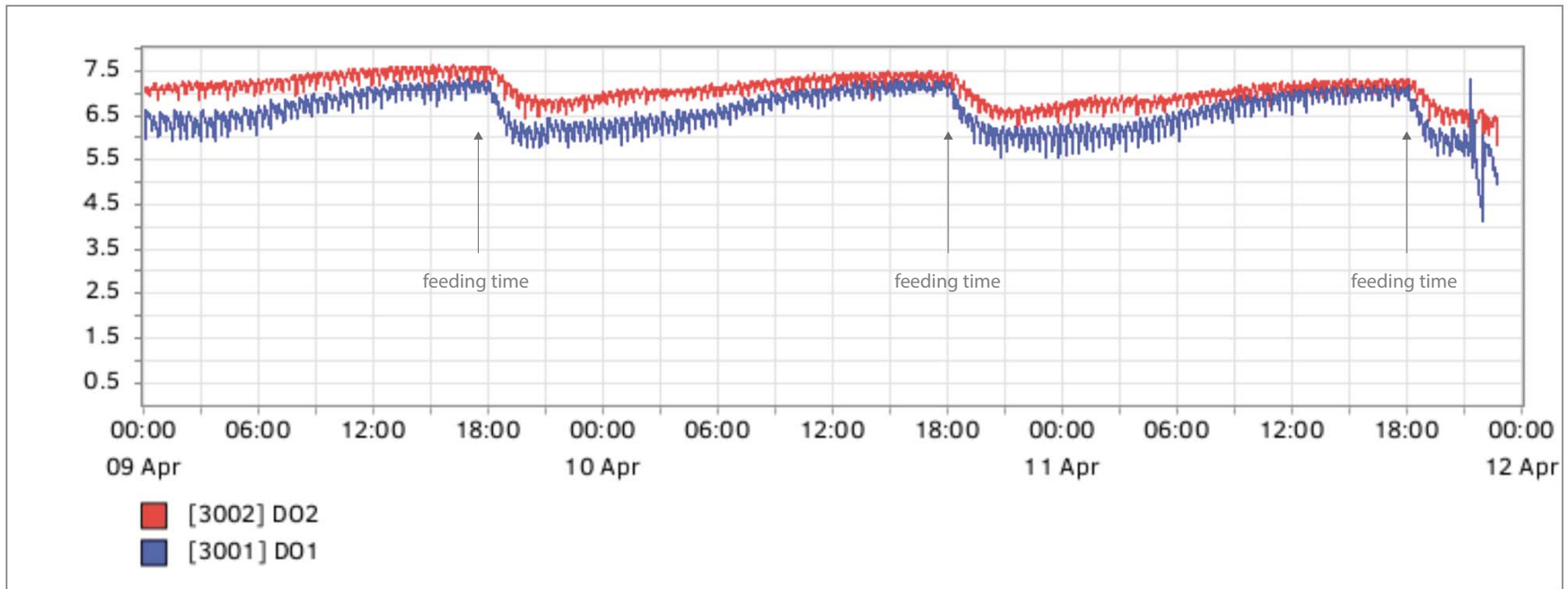



Method:

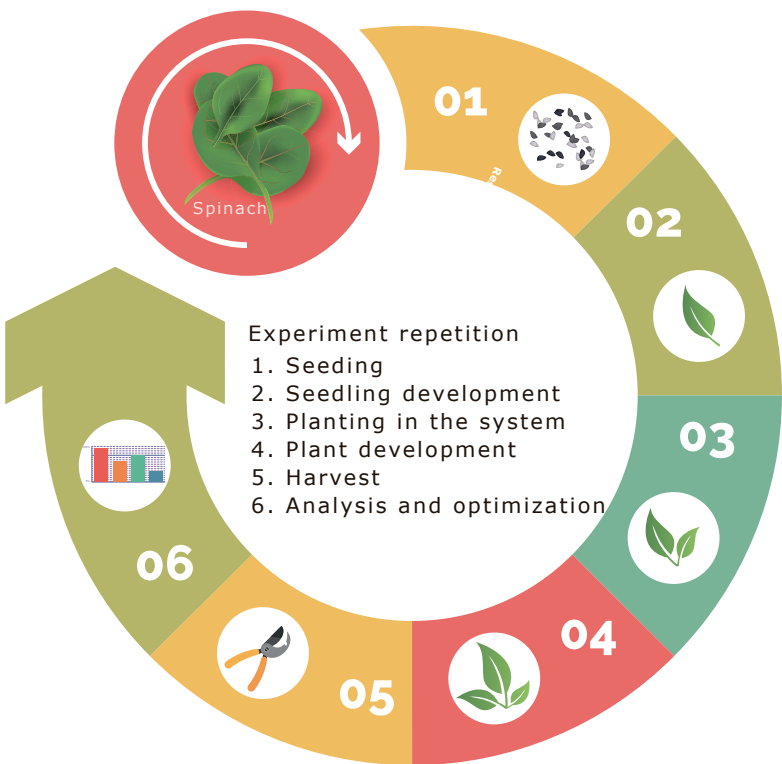

Plant measurements



Fish measurements



Nutrient solution measurements



Environmental parameters

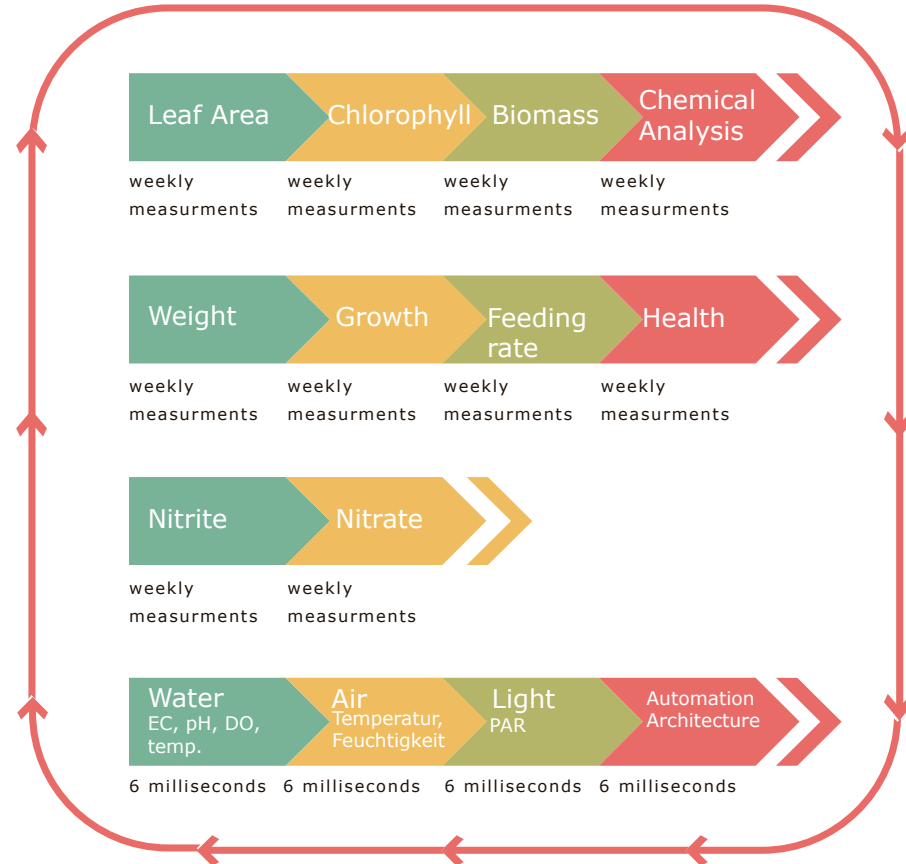



Mathematical modelling:

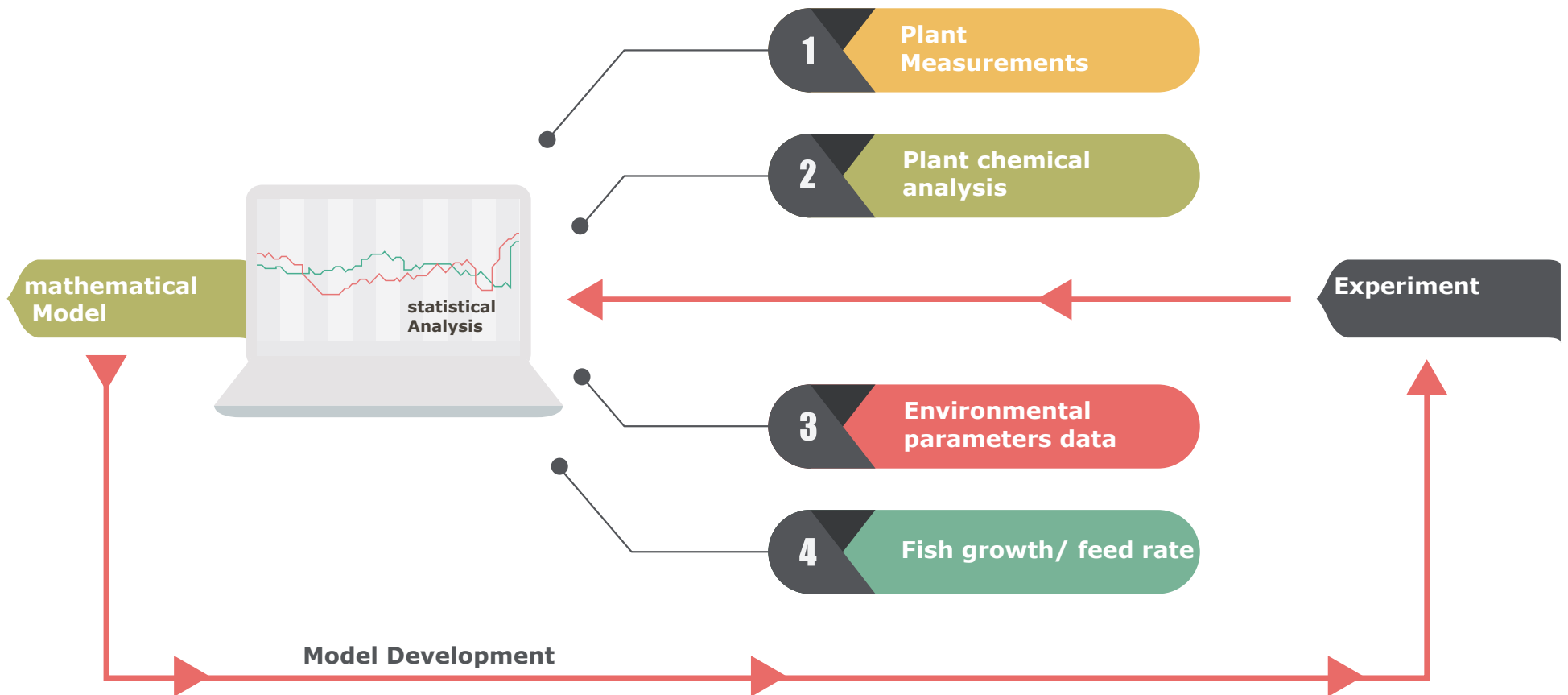



Different light intensities experiment:

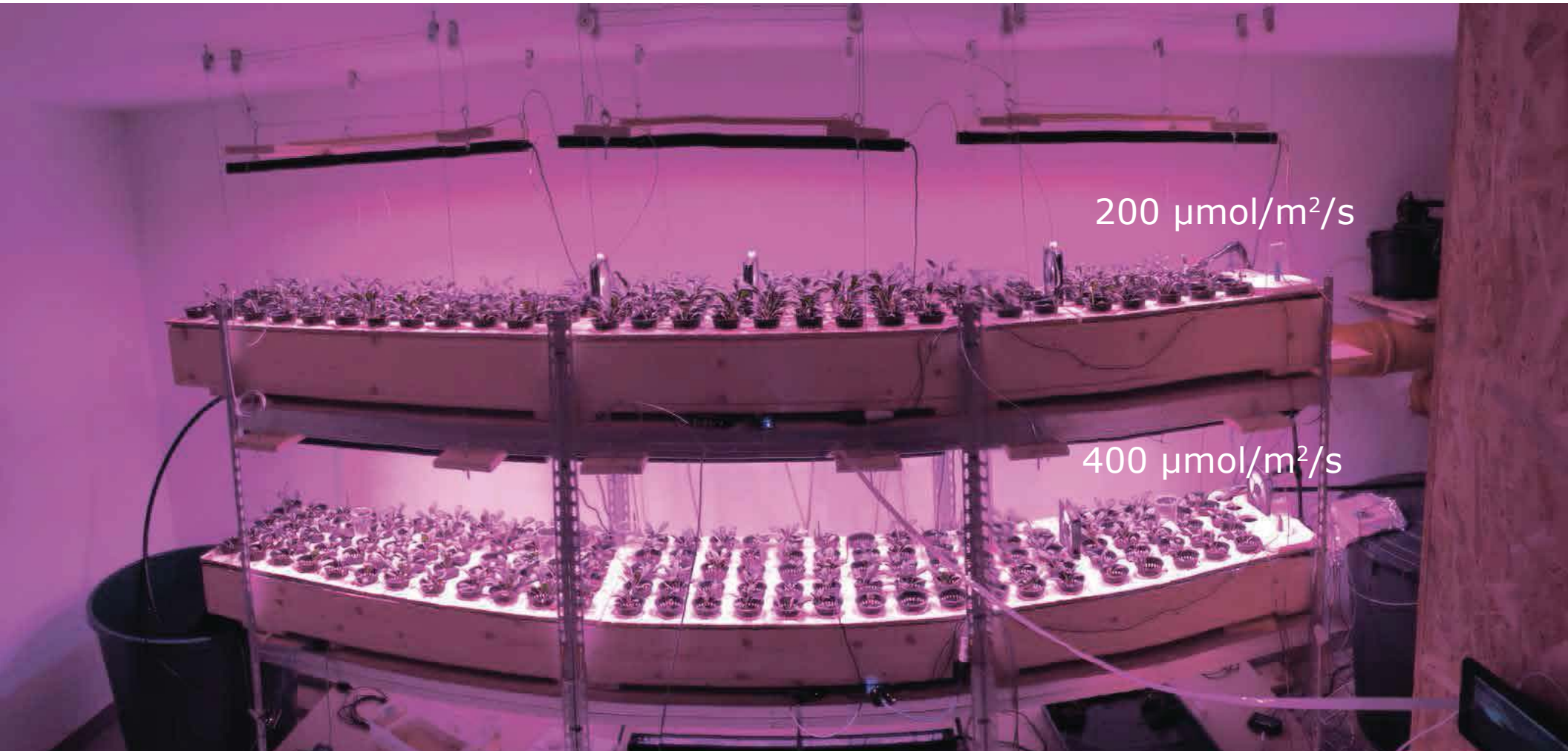



Preliminary results:

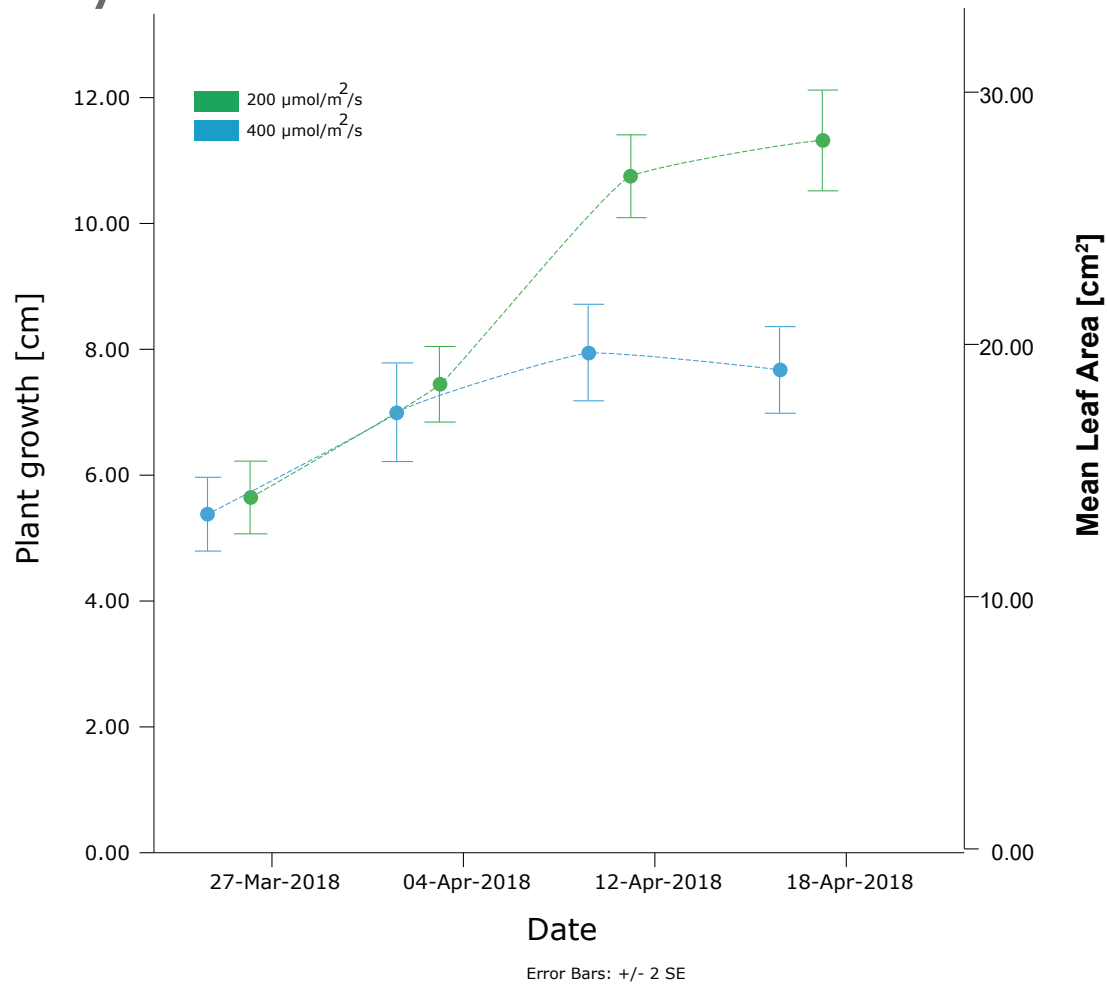



Preliminary results:

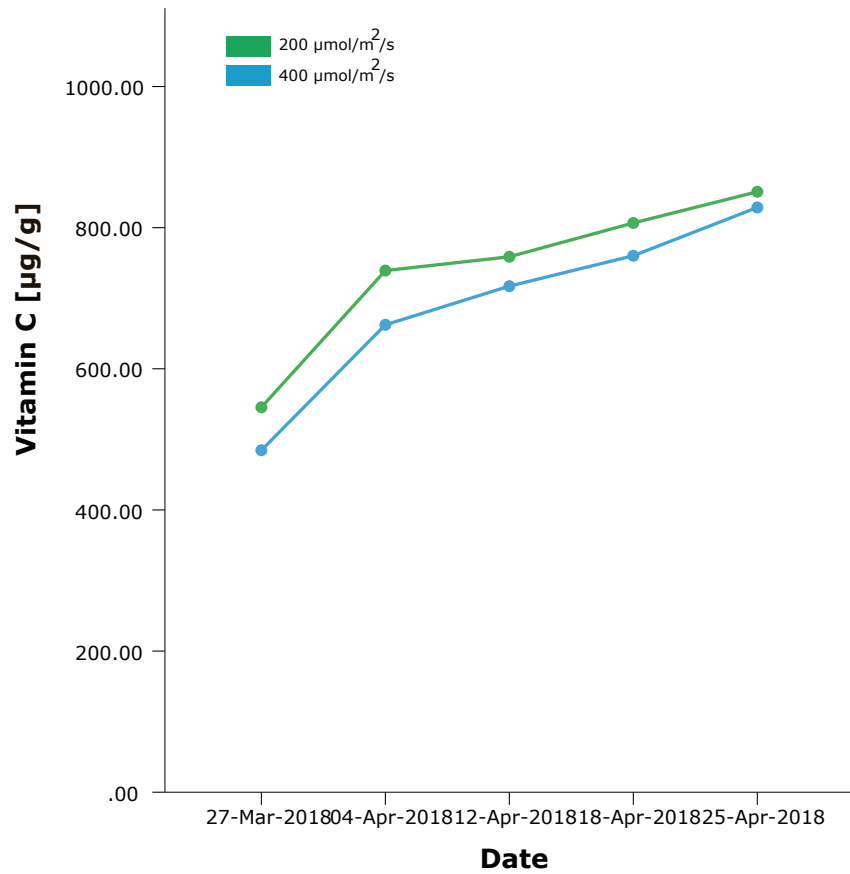



Preliminary results:

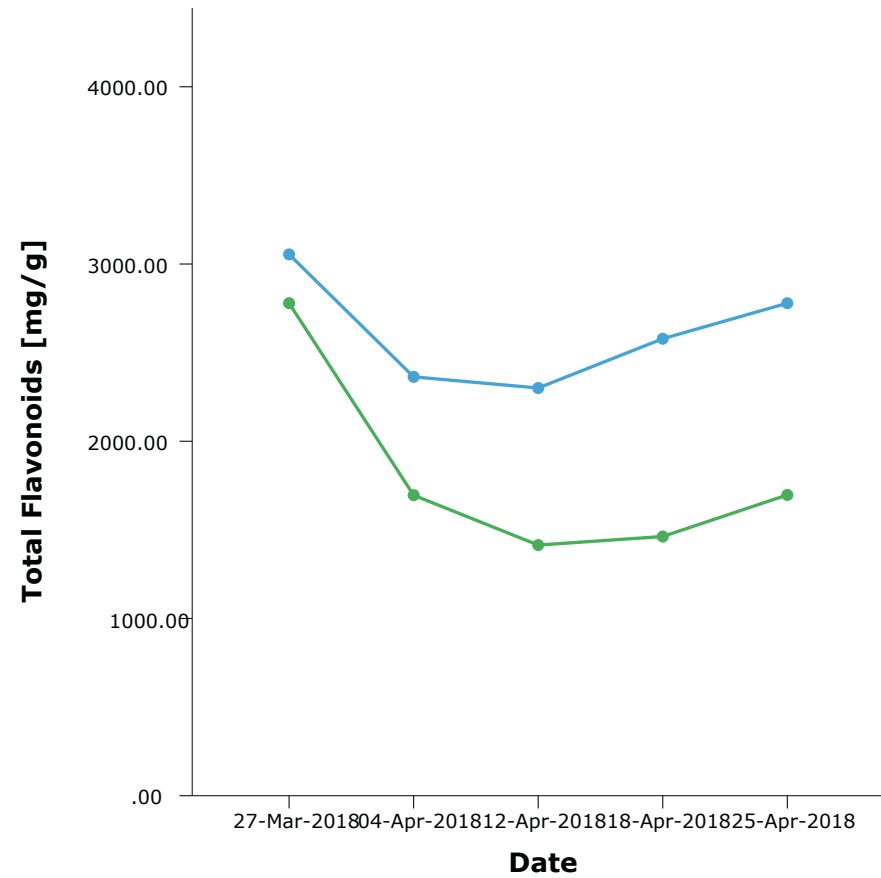
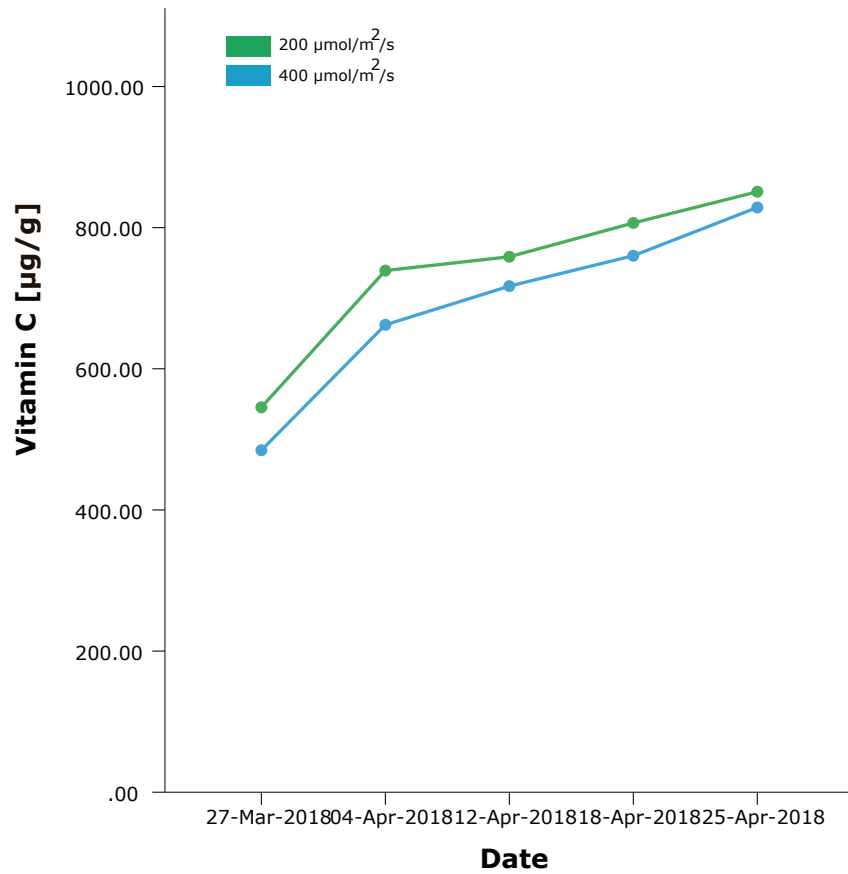



Preliminary results:

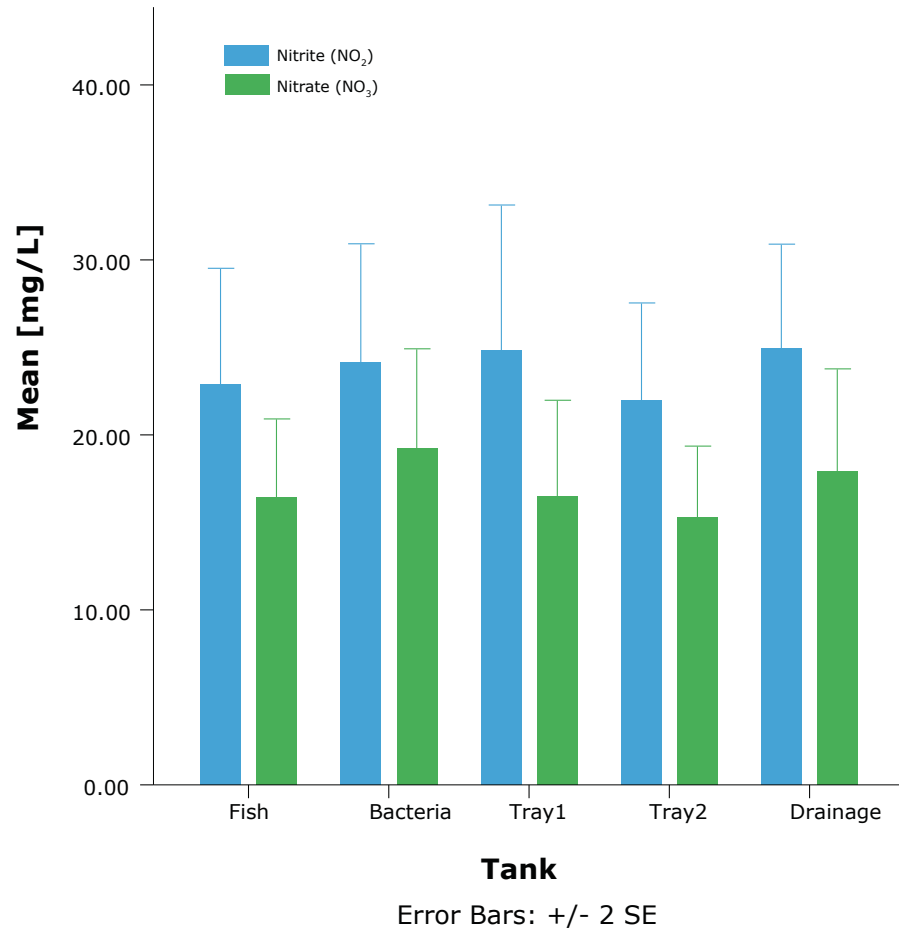



Preliminary results:

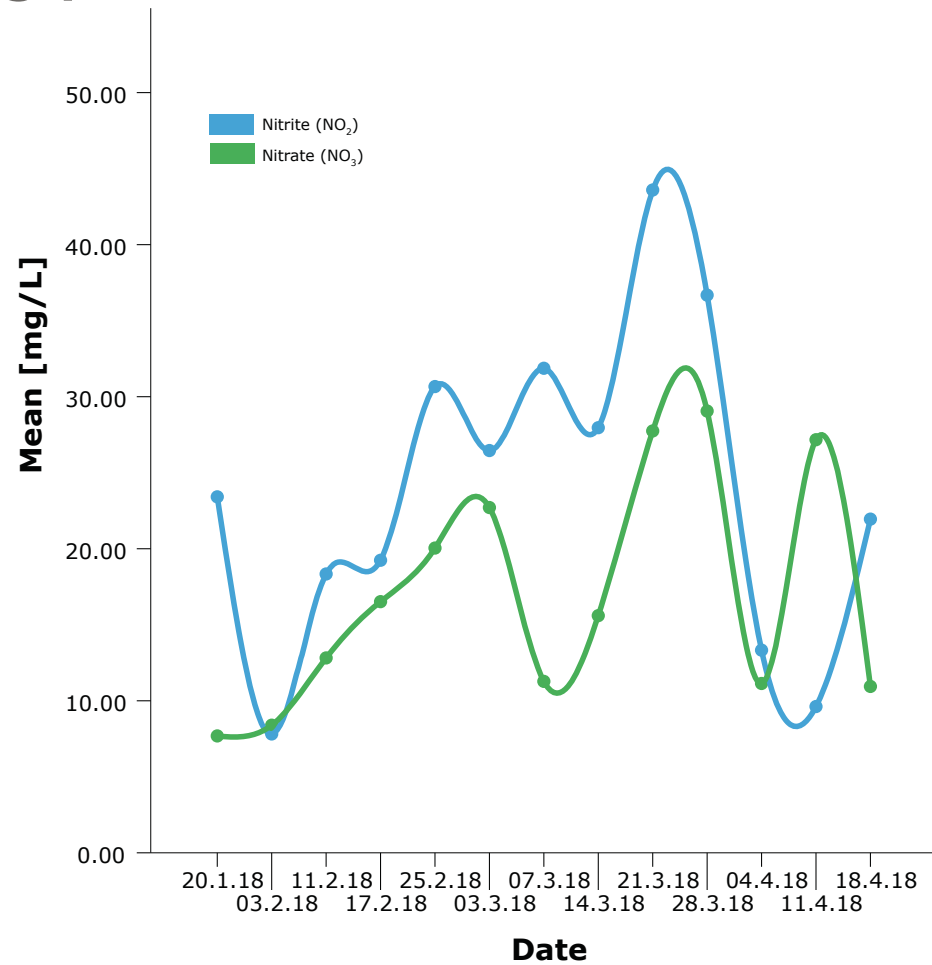
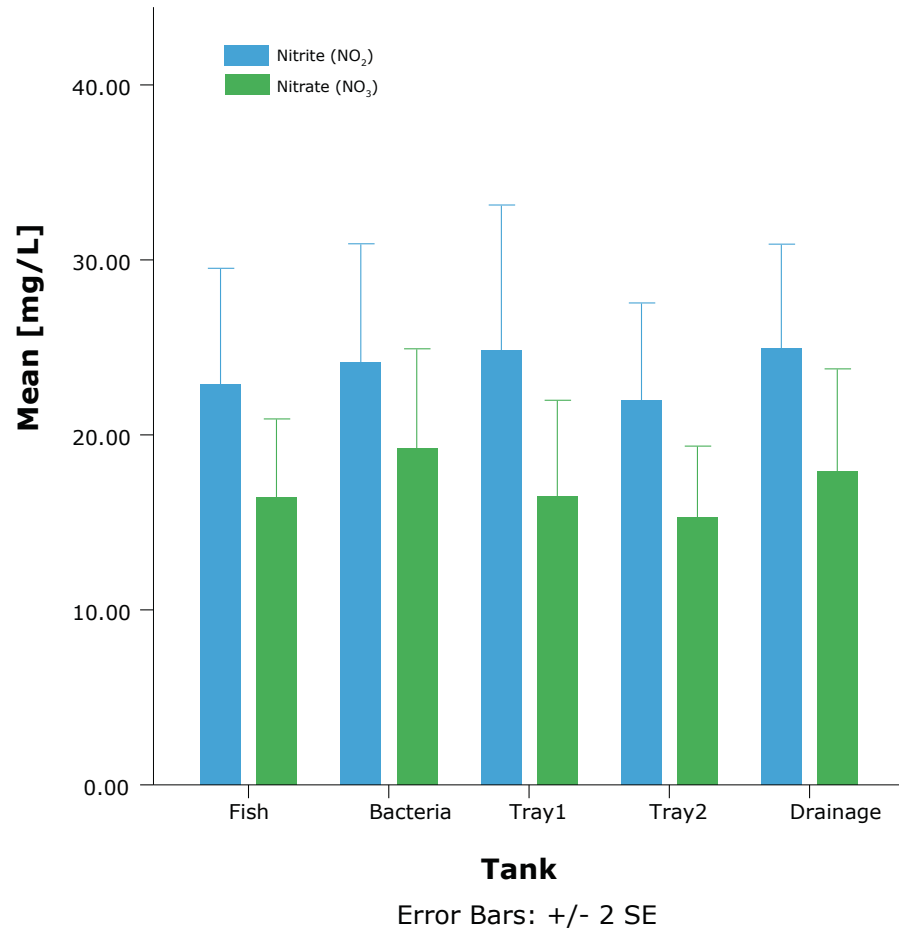



Preliminary results:

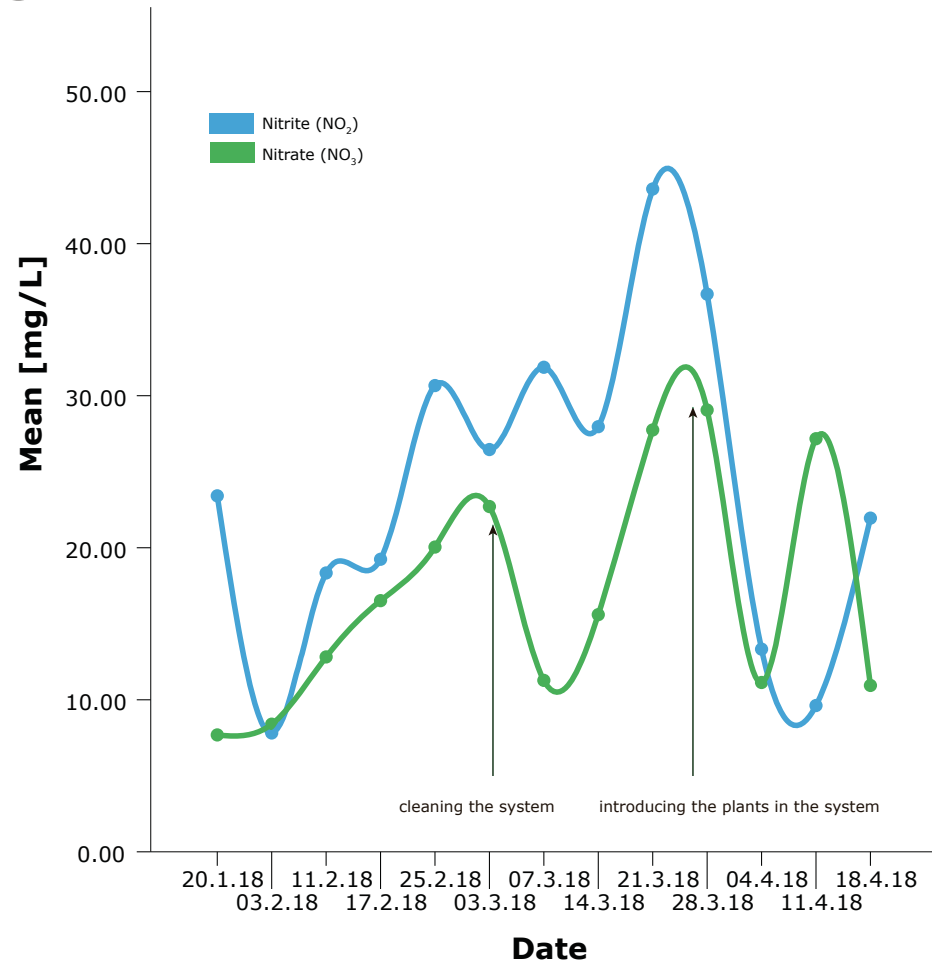
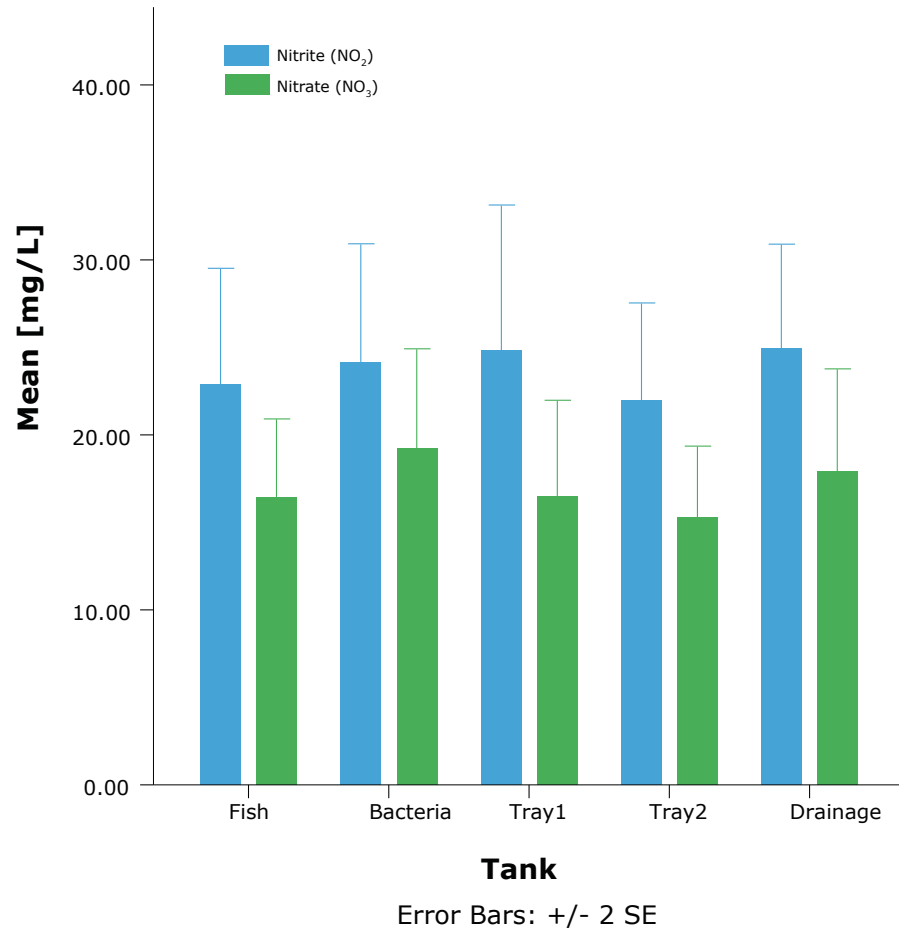



Preliminary results:

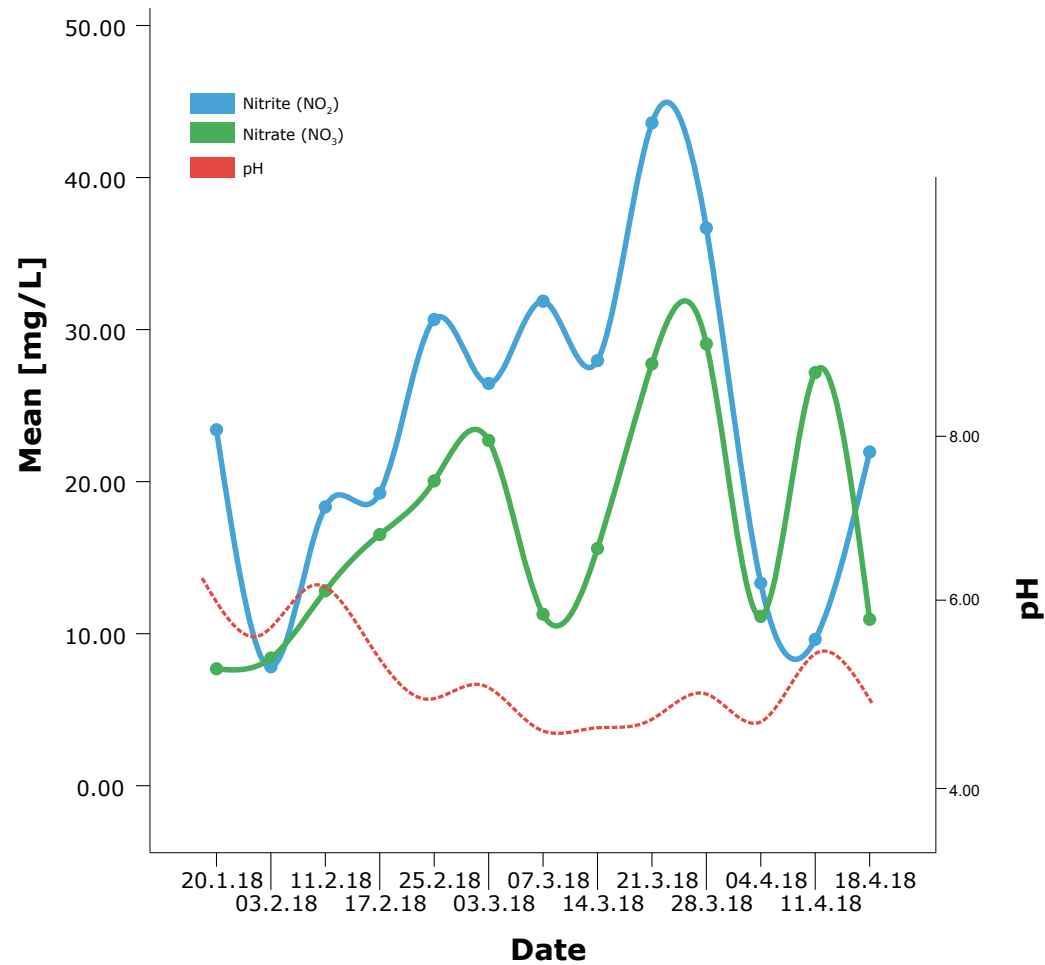



Next steps:





MARS. PLOT# 95

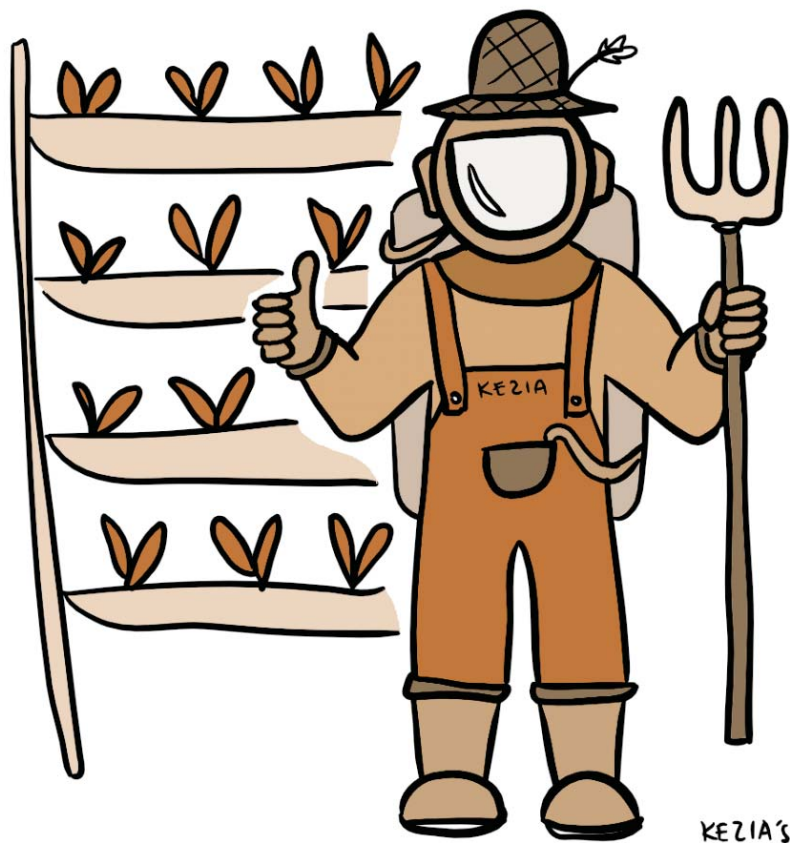

Thank you!

Dr. Rares C. Nistor, Eng. Voicu M. Stanese
Dr. Dan C. Vodnar, Msc. Bogdan Rusu
Dr. Floricuta Ranga, Dr. Manfred Koehler
Msc. Karina Kantor, Dr. Radu M. Giurgiu



Hochschule Neubrandenburg
University of Applied Sciences



plantgeek.eu

