

Memorandum of Understanding 19071/05/NL/CP



MELISSA FOOD CHARACTERIZATION: PHASE 1

TECHNICAL NOTE: 98.4.11

**TEST PLAN AND PROCEDURES FOR A
PRELIMINARY TRADE-OFF OF THE CROP
CULTIVAR.**

prepared by/ <i>préparé par</i>	Laury Chaerle, Martin Weihreter
reference/ <i>référence</i>	Contract number 22070/08/NL/JC
issue/ <i>édition</i>	1
revision/ <i>révision</i>	0
date of issue/ <i>date d'édition</i>	26.11.2009
status/ <i>état</i>	Final
Document type/ <i>type de document</i>	Technical Note
Distribution/ <i>distribution</i>	FC1 consortium, ESA/ESTEC

C O N F I D E N T I A L D O C U M E N T

A P P R O V A L

Title <i>titre</i>	Preliminary trade-off for test plan and procedures	issue <i>issue</i>	1	revision 0 <i>revision</i>
-----------------------	--	-----------------------	---	-------------------------------

author <i>auteur</i>	FCI Consortium	date <i>date</i>	18.09.2009
UBern	Valerie Page, Urs Feller		
UCL	Muriel Quinet, Stanley Lutts		
UGent	Laury Chaerle, Benjamin Secco, Martin Wehreter, Dominique Van Der Straeten		
UoGuelph	Michael Stasiak, Mike Dixon		
UNapoli	Roberta Paradiso, Stefania De Pascale		

Reviewed by (UGent)	Martin Wehreter	date	18.09.2009
approved by (UGent)	Laury Chaerle	date	26.11.2009
	Dominique Van Der Straeten		27.11.2009
Consultant	Claude-Gilles Dussap (UBP)		06.11.2009

C H A N G E L O G

reason for change / <i>raison du changement</i>	issue/ <i>issue</i>	revision/ <i>revision</i>	date/ <i>date</i>

C H A N G E R E C O R D

Issue: 1 Revision: 0

reason for change/ <i>raison du changement</i>	page(s)/ <i>page(s)</i>	paragraph(s)/ <i>paragraph(s)</i>

T A B L E O F C O N T E N T S

Table of Figures	vi
List of Tables	viii
List of Abbreviations	ix
Glossary	ix
1 Introduction	1
1.1 Hardware and monitoring parameter overview	2
2 Bread Wheat (UBern)	3
2.1 Growth chamber specifications	4
2.1.1 Dimensions.....	4
2.1.2 Lighting	4
2.1.3 Environment control.....	6
2.2 Hydroponic system	9
2.2.1 Hydroponic system setup	9
2.2.2 Hydroponic system materials	10
2.2.3 Pumps	10
2.2.4 Substrate	12
2.2.5 Nutrient solution composition	12
2.2.6 Hydroponic system sensor	13
2.2.7 Cooling system for the nutrient solution	13
2.2.8 Gullies cleaning.....	14
2.3 Test plan	14
2.3.1 Cultivar selected	14
2.3.2 Seeds treatment	15
2.3.3 Plant cultural condition	16
2.3.4 Plant growth period	18
2.3.5 Nutrient solution analysis	18
2.3.5.1 Macronutrients: N P K Ca Mg S in the nutrient solution.....	18
2.3.5.2 Micronutrients: Fe Mn Zn Cu Mo Cl Ni in the nutrient solution.....	18
2.3.6 Kernel analysis	19
2.3.6.1 Macronutrients in the kernels	19
2.3.6.2 Micronutrients in the kernels.....	19
2.3.7 Food quality analysis.....	19
2.3.8 Plant development	19
2.3.9 Biomass data	20
2.3.10 Yield estimation	20

2.3.11	Timing of the measurements	20
2.3.12	Reference of the measuring devices	21
2.4	Preliminary testing	22
2.5	References	22
3	<i>Durum Wheat (UGuelph)</i>	23
3.1	Growth Chamber Specifications	24
3.1.1	Dimensions	24
3.1.2	Construction materials used	24
3.1.3	Analysers	24
3.1.4	Lighting	24
3.1.5	Hydroponic system sensors	26
3.1.6	Chamber sensors	26
3.1.7	Environment control	26
3.1.8	Control system	27
3.1.9	Air handling	27
3.1.10	Nutrient delivery system	27
3.1.11	Pressure compensation	27
3.2	Test plan	30
3.2.1	Objective	30
3.2.2	Growing period	30
3.2.3	Crop growth procedures	30
3.2.4	Sampling and analysis	33
3.2.5	Analytical methods	33
3.3	References	35
4	<i>Potato</i>	36
	<i>Potato (UGent)</i>	36
4.1	Growth chamber specifications	37
4.1.1	Dimensions	37
4.1.2	Lighting	37
4.1.3	Environment control	40
4.1.3.1	Air temperature and relative humidity	40
4.1.3.2	Settings and error limits	41
4.2	Hydroponic system	43
4.2.1	Hydroponic system explanation	43
4.2.2	Hydroponic system material	46
4.2.3	Pumps	46
4.2.4	Substrate choice	46
4.2.5	Nutrient solution composition	46
4.2.6	Hydroponic system sensors	47

4.2.7	Gully cleaning	49
4.3	Experimental protocol	49
4.3.1	Cultivar selected	49
4.3.2	Acclimated in vitro-plants treatment	50
4.3.3	Culture conditions	50
4.3.4	Plant growth period	51
4.3.5	Nutrient Solution Sampling.....	51
4.3.6	Plant development	51
4.3.7	Gas exchange measurements.....	51
4.3.8	Imaging of leaf area and leaf temperature	51
4.3.9	Biomass data	52
4.3.10	Yield estimation	52
4.3.11	Timing of the measurements	52
4.3.12	Preliminary testing	54
Potato (UCL)		55
4.4	Growth chamber specifications.....	55
4.4.1	Lighting	56
4.4.2	Environment control.....	58
4.4.3	Hydroponic system.....	61
4.4.4	Nutrient solution.....	63
4.4.5	Microorganisms monitoring	63
4.5	Test plan	64
4.5.1	Setup and protocol for germination and propagation	64
4.5.2	Observation parameters for the plants.....	64
4.6	Summary	68
5	Soybean.....	69
5.1	Growth chamber specifications.....	69
5.1.1	Hydroponics system	69
5.1.2	Environment control.....	70
5.1.3	Experimental set up.....	71
5.2	Test plan	76
5.2.1	Sampling and Measurements	76
5.2.1.1	Plant growth and physiology	76
5.2.1.2	Water consumption and nutrient uptake.....	77
5.2.1.3	Yield performance	78
5.2.1.4	Growth and Efficiency Indexes.....	78
5.2.1.5	Cultivation system requirements and critical points identification	78
5.2.2	References of the measuring devices	79
5.2.3	References	80

5.3	Seed and product analysis	81
5.3.1	Dry mass.....	81
5.3.2	Fat content.....	81
5.3.3	Protein content.....	81
5.3.4	Fibre content.....	81
5.3.5	Carbohydrate content	82
5.3.6	Phytic acid analysis	82
5.3.7	Isoflavones analysis.....	83
5.3.8	Analysis plan	85
5.3.9	References of the measuring devices	86
5.3.10	References	87

Table of Figures

Fig. 1	Growth chamber with equipment installed	3
Fig. 2	Scheme of the growth chamber with gullies numbered from A1 to D2	4
Fig. 3	Point of light intensity measurement above the gully	4
Fig. 4	Light intensity mapping above the 8 gullies	5
Fig. 5	Spectrum of the light tube Osram FQ 39 W/ 830 HO Lumilux warm white.....	6
Fig. 6	Spectrum of the light tubes Osram FQ 39 W/ 840 HO Lumilux cold white.....	6
Fig. 7	Placement of thermometers and hygrometers in the growth chamber	7
Fig. 8	Temperature profile at gullies level and in the tank of gully D2	8
Fig. 9	Relative humidity in the growth chamber	8
Fig. 10	Top view of the growth chamber with emplacement of the 8 gullies	9
Fig. 11	Front cross section of a gully	10
Fig. 12	Scheme of the hydroponic system.....	11
Fig. 13	Front view of the Grodan Plugs (piece of 10 cm)	12
Fig. 14	Emplacement of the Rockwool pieces in the gully	12
Fig. 15	Developmental stage of the wheat grain selected for transfer to rockwool	16
Fig. 16	Grain of wheat in the hole of the rockwool.....	16
Fig. 17	Placement of the spring wheat cultivars in the growth chamber.....	17
Fig. 18	Scheme of the gully and the Rockwool.....	17
Fig. 19	Ears of plant from the preliminary experiment. The stamens are visible.....	20
Fig. 20	Pre-test with the four spring wheat cultivars.....	22
Fig. 21	View on the SEC2 growth chambers	23
Fig. 22	Photon flux in $\mu\text{mol}/\text{m}^2\text{s}$ measured 135 cm from the floor.....	25
Fig. 23	Photon flux in $\mu\text{mol}/\text{m}^2\text{s}$ measured 100 cm from the floor.....	25
Fig. 24	Measurement locations for light mapping (not to scale).....	26
Fig. 25	Side schematic of one of the UoG sealed environment plant growth chambers.....	28
Fig. 26	Top view schematic showing hydroponic tray location.....	28
Fig. 27	Nutrient system schematic	29
Fig. 28	Temperature and Humidity control in a 56 day old soybean crop.	29
Fig. 29	Setup of troughs and plant positioning within the growth chamber	31

Fig. 30	Growth chamber with equipment installed	36
Fig. 31	Schema of the growth chamber with gullies numbered from 1 to 4.	38
Fig. 32	Point of light intensity measurement above the rack	38
Fig. 33	Light flux mapping above rack 1 (higher) and 2 (lower).	39
Fig. 34	Spectrum of the light tube MASTER TL-D Reflex 58W/840	39
Fig. 35	Air input (rack 1) and output (rack 3) temperature, dark period from 0 to 8 AM... 41	
Fig. 36	Day and night temperature mapping on rack 1	42
Fig. 37	Relative humidity in the growth chamber – dark period 0 – 8 AM	42
Fig. 38	Front view of a trough	44
Fig. 39	Schematic of the hydroponic system.....	44
Fig. 40	Schematic of the water handling system	45
Fig. 41	Response of the nutrient solution pH to the automated acid addition.....	48
Fig. 42	Response of the nutrient solution EC to the automated base addition	49
Fig. 43	Potato vitro-plants after acclimatisation.....	50
Fig. 44	Tubers produced from the preliminary experiment.....	54
Fig. 45	Schematic representation of the growth room in Louvain-la-Neuve	55
Fig. 46	Philips TL-D reflex super 80 58W/840 specification and spectrum	56
Fig. 47	Map of the light ceiling	57
Fig. 48	Light intensity along the gullies with standard deviation between gullies.	57
Fig. 49	RH and temperature on table1 next to the door and the fan unit.....	58
Fig. 50	RH and temperature on table2.....	59
Fig. 51	RH and temperature in the middle of the room (no direct contact with the lamps) 59	
Fig. 52	Temperature control system in the growth room	60
Fig. 53	Recirculating closed NFT hydroponic system for potatoes.	61
Fig. 54	Gullies and hydroponic systems.....	62
Fig. 55	Views of the double gully, the nutrient solution tank and the submerged pump. ...	72
Fig. 56	Air conditioning system in the growth chamber and reflective film on the floor. ..	72
Fig. 57	Plastic basket for seeds and plants holding in the NFT gullies.	73
Fig. 58	The emission spectrum of HPS lamps LU600/T GE Lucalox® T15 - 600 W.....	73
Fig. 59	Layout of the gullies and the climate control devices.....	74
Fig. 60	Position of the measurements in relation to the lamps.....	74
Fig. 61	Virtual spatial light distribution in the growth chamber.	74
Fig. 62	Temperature at the height of the gullies	75
Fig. 63	Random distribution of the soybean cultivars in the growth chamber.....	76
Fig. 64	Schedule of the measurements on plant and crop and on nutrient solution.	79
Fig. 65	A typical liquid chromatograph.....	85

List of Tables

Tab. 1	Nutrient solution recipe for start-up solution and replenish tank solution	13
Tab. 2	Characteristics of the spring wheat cultivars selected for the FC phase 1	15
Tab. 3	Timing of the measurements	21
Tab. 4	Nutrient solution recipe for 150 L start-up and 10L replenish tank solution	32
Tab. 5	Sample requirements	34
Tab. 6	Photoperiod and light range	37
Tab. 7	Light flux in function of the plant position	37
Tab. 8	Sensors for online measurement of required environmental parameters	43
Tab. 9	Growing phase nutrient solution composition	47
Tab. 10	Tuberisation phase nutrient solution composition	47
Tab. 11	Sensors choice for online measurement of required environmental parameters	47
Tab. 12	Characteristics of the potatoes cultivars selected for the FC phase 1	49
Tab. 13	Cultivars selected and quantity of plants.....	51
Tab. 14	Potato tuber nutrient analysis	52
Tab. 15	Parameters and frequency of logging	53
Tab. 16	Specifications of the Symphony SP90M5 meter (pH, EC, O ₂ , temperature).....	63
Tab. 17	Test sticks specifications	64
Tab. 18	Specifications of instruments for physiological parameters.....	65
Tab. 19	Salt composition of the nutrient solution (mg per litre of nutrient solution).	70
Tab. 20	Vertical and horizontal light distribution ($\mu\text{mol}/\text{m}^2\text{s}$ average of 5 replicates)....	75
Tab. 21	Vertical and horizontal temperature distribution ($^{\circ}\text{C}$; average of 5 replicates) ..	75
Tab. 22	Vertical and horizontal RH distribution (%; average of 5 replicates).....	75
Tab. 23	Characterization of isoflavones present in soybean and soymilk extracted	84
Tab. 24	Amount of soybeans, we need for every analysis and in total.	85

List of Abbreviations

AAS:	Atomic Absorption Spectrophotometry
CES:	Controlled Environment Systems
CESRF:	Controlled Environment Systems Research Facility
DAP:	Days After Planting
DI:	Deionised
DM:	Dry Matter
EC:	Electrical Conductivity
FID:	Flame Ionization Detector
FW:	Fresh weight
GC:	Gas Chromatograph
HDPE:	High-density polyethylene
HPLC:	High Pressure Liquid Chromatograph
ICP:	Inductive Coupled Plasma
LA:	Leaf area
LC-MS/MS:	Liquid chromatography-mass spectrometry
MDL:	Minimum Detection Limit
NFT:	Nutrient Film Technique
OD:	Optical Density
PAR:	Photosynthetic active radiation
PCA:	Plate Count Agar
PE:	Polyethylene
PP:	Polypropylene
PPF:	Photosynthetic Photon Flux
PU:	Polyurethane
RH:	Relative Humidity
SEC-2:	Sealed Environment Chambers
TDF:	Total Dietary Fibre
TVC:	Total Viable Count
VOC:	Volatile Organic Compound
VPD:	Vapour Pressure Deficit
YGC:	Yeast extract Glucose Carbonate medium

Glossary

Gully: also known as trough or gutter. Inclined channel used in hydroponic systems to hold the plant root system, and where the nutrient solution flows through.

1 Introduction

This Technical Note is the result of contributions from members of the project consortium, and was compiled by the management team at UGent. It describes the facilities used to cultivate four different cultivars for each of the 4 crops selected for the FC project, and outlines the experimental procedures for the WP 4200 tasks. Each partner has its own growth chamber setup based on different hardware. The goal of this work is to unify the test procedures as far as possible despite the differences in chamber hardware, crop cultivation needs and availability of measuring equipment.

In all setups, the liquid phase is separated for all cultivars selected. From the 5 available setups, only the Guelph chambers feature a sealed atmosphere in which one cultivar at a time is grown. Hence only the measurements from the Guelph setup can be used for mass-balance assessments as a function of time. The other setups grow the cultivars in a common atmosphere. To avoid inhibitory effects on plant growth, the solution of the recirculating hydroponic systems will be replaced during plant development.

The gathered crop growth data, corresponding to the involved labs measuring schedules for the defined parameters, will be summarised with the use of a standardised template provided by UGent. A link with the associated harvest analysis data will be defined for inclusion into the MELiSSA Food Database structure.

To guarantee reliability and traceability of the data, each partner has been requested to include a monthly overview of the overall chamber status (including possible failures etc.) into the aforementioned template. Each partner adapts this template to their specific measuring schedule as defined in this document.

The experience gained from these plant production trials will be used to evaluate and define the PCU design requirements.

TN 98.4.11	Preliminary trade-off for test plan and procedures
UGent	
<p>This document is confidential property of the MELiSSA partners and shall not be used, duplicated, modified or transmitted without their authorization</p> <p>Memorandum of Understanding 19071/05/NL/CP</p>	

1.1 Hardware and monitoring parameter overview

The basic hardware characteristics and the common monitoring parameters for the first bench-test of Phase 1 of the FC project are listed below. The details of the respective setups and the associated measuring schedules for the comparison of the performance of 4 cultivars per crop are elaborated in this document.

Controlled environment chamber hardware

Atmosphere UoGuelph: 2 sealed chambers,
1 cultivar per chamber, 2 subsequent experiments
UGent, UNapoli, UBern, UCL: walk in chamber
common atmosphere for 4 cultivars, 1 experiment

Liquid phase Independent recirculating NFT system per cultivar

UGent, UNapoli, UBern, UCL: 4 independent setups in 1 chamber

UoGuelph: 1 setup per chamber, 4 independent experiments

Monitoring parameters

Growth environment:

-light, chamber temperature and relative humidity evolution, CO₂ level

Nutrient solution environment:

-gully flow, inclination and solution layer thickness; pH and EC control; nutrient solution T

-nutrient solution elemental analysis

Plant growth assessment:

-assessment of development: height, branching, flowering, seedset or tuberisation

-gas-exchange measurements: assimilation and transpiration (CO₂, H₂O)

UGent, UNapoli, UBern, UCL: short-term using open-circuit gas exchange systems

UoGuelph: continuous whole chamber CO₂ usage and crop transpiration monitoring

TN 98.4.11	Preliminary trade-off for test plan and procedures
UGent	
This document is confidential property of the MELiSSA partners and shall not be used, duplicated, modified or transmitted without their authorization Memorandum of Understanding 19071/05/NL/CP	

2 Bread Wheat (UBern)

The growth chamber at the University of Bern was modified in order to fulfil all the growth conditions as specified in the proposal for MELiSSA Food Characterisation Phase 1.

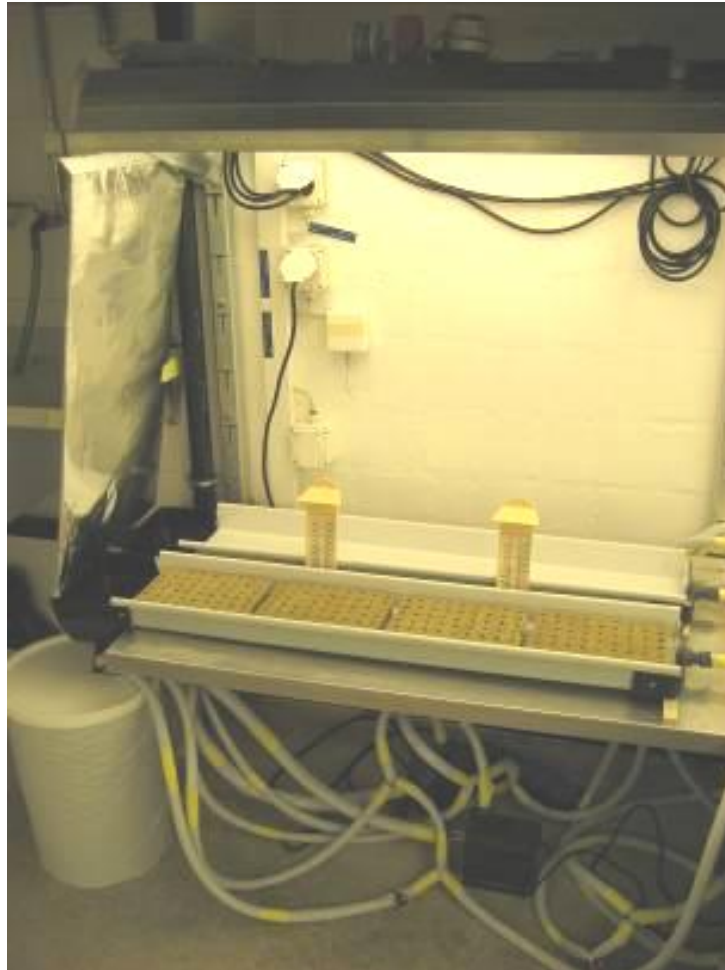

Fig. 1 Growth chamber with equipment installed

TN 98.4.11	Preliminary trade-off for test plan and procedures
UGent	
This document is confidential property of the MELiSSA partners and shall not be used, duplicated, modified or transmitted without their authorization Memorandum of Understanding 19071/05/NL/CP	

2.1 Growth chamber specifications

2.1.1 Dimensions

Growth chamber area: 8.32 m² (3.05 m x 2.73 m)

Plant growing area: 1.52 m² (1 m x 0.19 m x 8)

Growth space between plant root support and lamps is 80cm (see 2.2.1).

2.1.2 Lighting

The same light distribution is present over each gully. Two types of lamps are placed alternatively in the lamp-module. The two types of lamps are:

1) Osram FQ 39 W/ 830 HO Lumilux warm white and

2) Osram FQ 39 W/ 840 HO Lumilux cold white.

Spectra are presented in Fig. 5 and Fig. 6. One lamp-module is made with four lamps of type 1 and four lamps of type 2. Six lamp-modules are placed on the six racks of the growth chamber, but only four racks are used for the placement of the gullies. The method of photoperiod control is: ON/OFF. The lamps turn on at 8:00 and turn off at 22:00. Reflectors were placed on the wall close to the entry side of the gullies D1/D2 and in between the sink and gullies A1/A2 (see also Fig. 2) to increase light intensity. A mapping of the light intensities was made 13 cm above the gullies (level of the first leaf), 40 cm above the gullies (canopy level when the plants are at the tillers formation developmental stage) and 60 cm above the gullies (level of the flag leaf). The ears extend above 60 cm (from preliminary experiment, the plant height was in between 65-75 cm). The gullies are numbered from A1 to D2 as seen in Fig. 2. Fig. 3 shows the measurement points. In Fig. 4, the results of the mapping are visible.

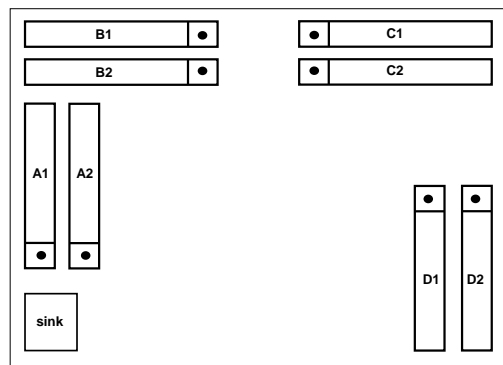

Fig. 2 Scheme of the growth chamber with gullies numbered from A1 to D2

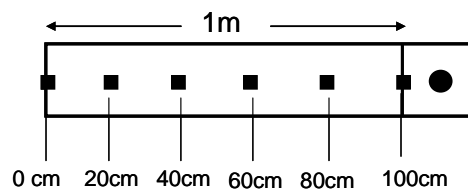

Fig. 3 Point of light intensity measurement above the gully

TN 98.4.11	Preliminary trade-off for test plan and procedures
UGent	
This document is confidential property of the MELiSSA partners and shall not be used, duplicated, modified or transmitted without their authorization	
Memorandum of Understanding 19071/05/NL/CP	

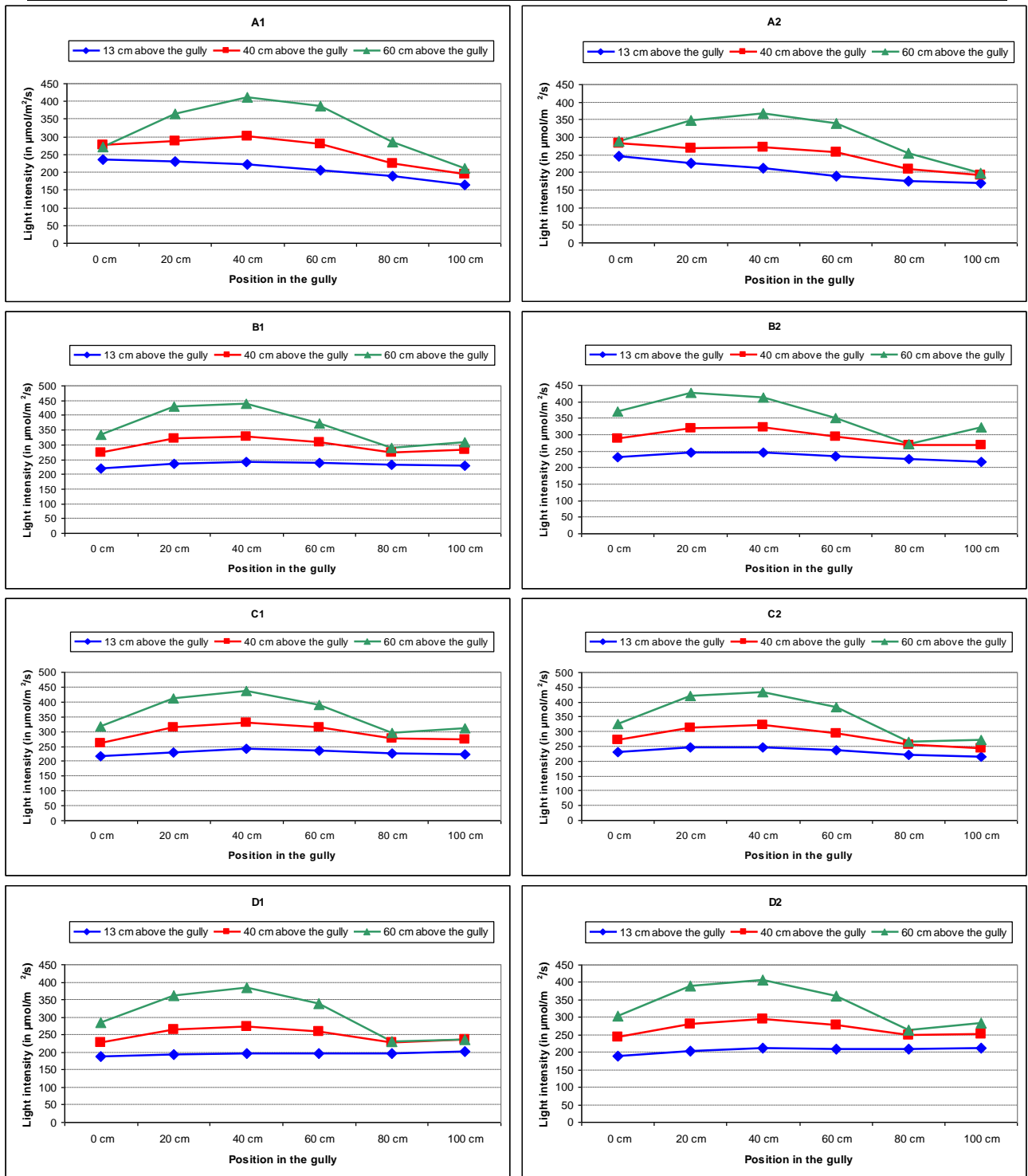

Fig. 4 Light intensity mapping above the 8 gullies

TN 98.4.11

UGent

Preliminary trade-off for test plan and procedures

This document is confidential property of the MELiSSA partners and shall not be used, duplicated, modified or transmitted without their authorization

Memorandum of Understanding 19071/05/NL/CP

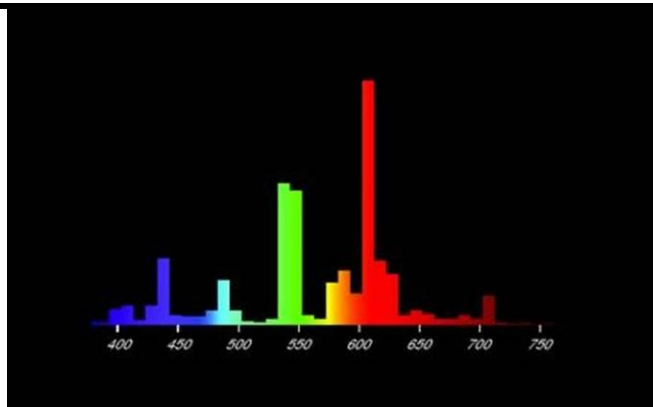

Fig. 5 Spectrum of the light tube Osram FQ 39 W/ 830 HO Lumilux warm white

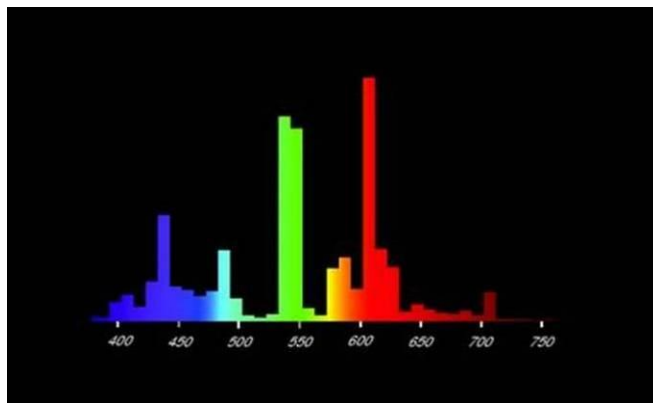

Fig. 6 Spectrum of the light tubes Osram FQ 39 W/ 840 HO Lumilux cold white

2.1.3 Environment control

Fresh air is injected in the growth chamber by an air replacement system working from 6:30 to 22:00. The fresh air comes from a central system where it is filtered and heated if needed (winter). The cooling system of the growth chamber consists of a unit with a central air intake and a dual cold air output in the direction of the entrance door and the back wall, respectively. The ventilation of the cooling system is continuous, cooling with chilled water from central unit building. The temperature setting is 22 °C during the day and 18°C during the night. The temperature of the air is measured at the plant level by 8 mercury thermometers placed between the gullies (see placement of thermometers in the Fig. 7). All thermometers have a min/max function and are placed on each bench located between positions ab and cd (see Fig. 7 and Fig. 14) Min/max temperatures are reset weekly. See the confirmation of the temperature target value in Fig. 8. The temperature of the growth chamber is measured and controlled via a sensor (Duct Temperature Sensors, C7068, Honeywell, GmbH, Germany) located at midlevel under lamp-module A1/A2 to remediate extra heat building up under lamp modules. The relative humidity is measured by a hygrometer (Fischer GmbH, Germany) located on the wall between the door and the gullies D1/D2 (combined plotting with temperature values, allowing

TN 98.4.11	Preliminary trade-off for test plan and procedures
UGent	
This document is confidential property of the MELiSSA partners and shall not be used, duplicated, modified or transmitted without their authorization	
Memorandum of Understanding 19071/05/NL/CP	

to calculate the temperature-independent vapour pressure deficit - VPD). The relative humidity is also measured by an additional sensor (TFA mechanical hair hygrometer, Germany). See Fig. 7 for the location of the hygrometers. See 2.3.12 for the specifications of the measuring devices. Excess humidity is removed through condensation by the cooling system. As a result the average relative humidity is approximately 65 % during the day and 75 % during the night. The measurement of relative humidity by the TFA sensor is shown in Fig. 9. The conditions of humidity in the growth chamber are good and a humidifier is not needed. If the conditions change and a humidifier is needed, a humidifier can be installed. A hygrometer (recording relative humidity and temperature for one week on a paper) was placed in the growth chamber close to the wall between the door and gullies D1/D2. The O₂ concentration is ambient. CO₂ concentration is measured with a handheld IRGA analyzer (Environmental Instruments, Anagas CD 95, Geotechnical Instruments, Leamington Spa, UK) weekly at chamber level, with air intake tube located in the culture room near the gullies. Monitoring of growth chamber parameters is foreseen by dedicated personnel. A safety thermostat turns off the lamps automatically in case the temperature exceeds 35°C). In case of increase of temperature or humidity, an alarm is sent to dedicated personnel. All the conditions of the growth chamber (turn on/off the lamps, turn on/off the air replacement, temperature setting, real temperature, humidity setting, real humidity, speed of ventilation) are saved. Reports can be printed choosing the period of interest (1 week, 1 month or 1 year, with more or less details).

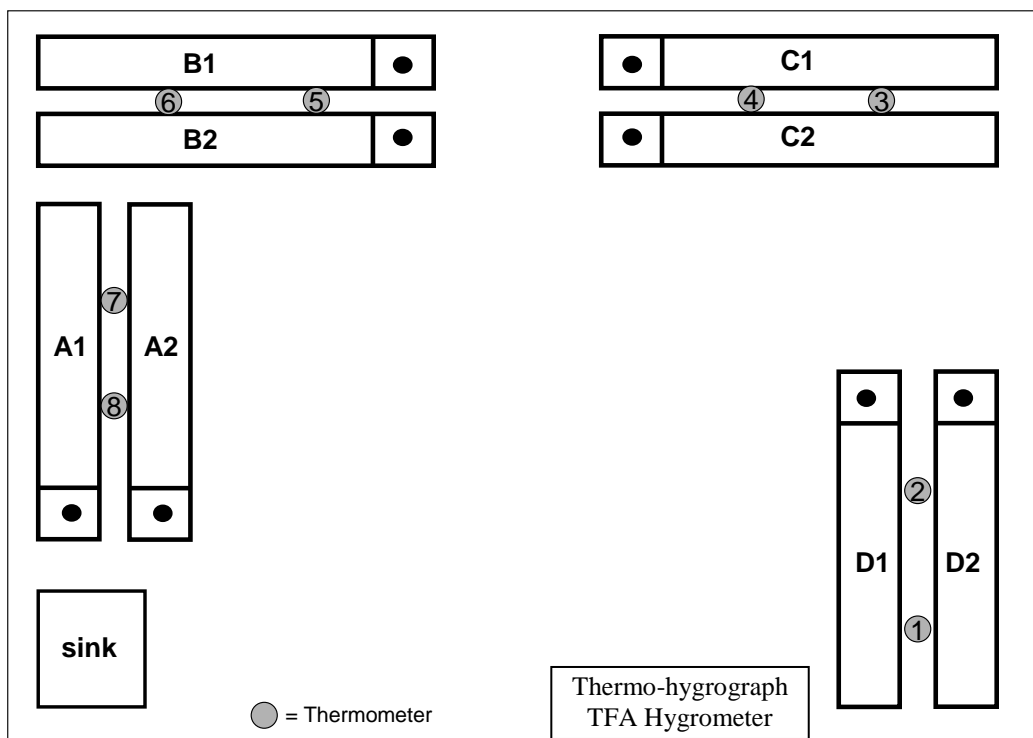

Fig. 7 Placement of thermometers and hygrometers in the growth chamber

TN 98.4.11	Preliminary trade-off for test plan and procedures
UGent	
This document is confidential property of the MELiSSA partners and shall not be used, duplicated, modified or transmitted without their authorization	
Memorandum of Understanding 19071/05/NL/CP	

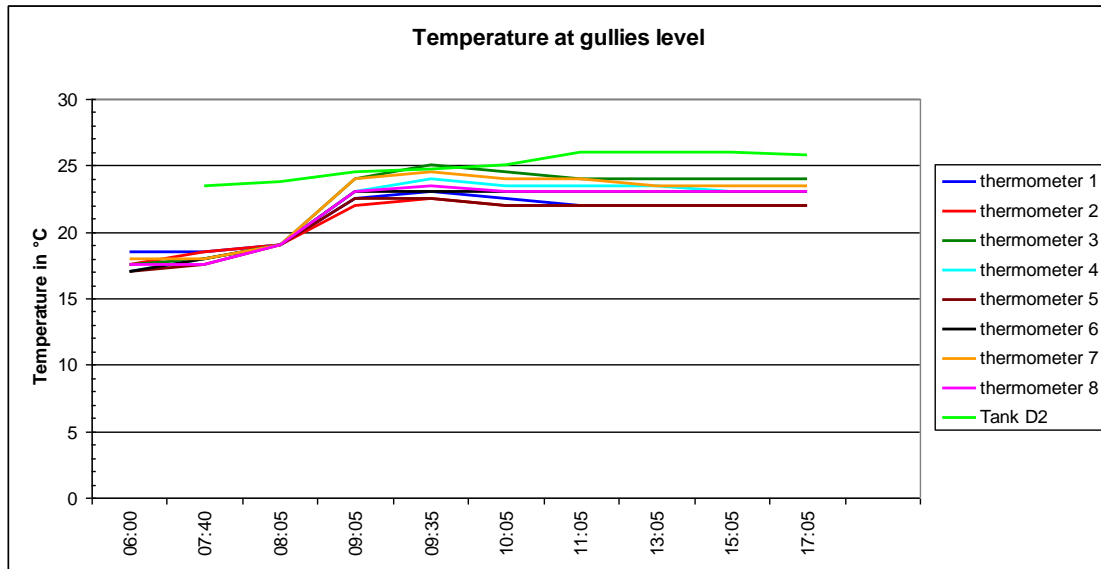

Fig. 8 Temperature profile at gullies level and in the tank of gully D2

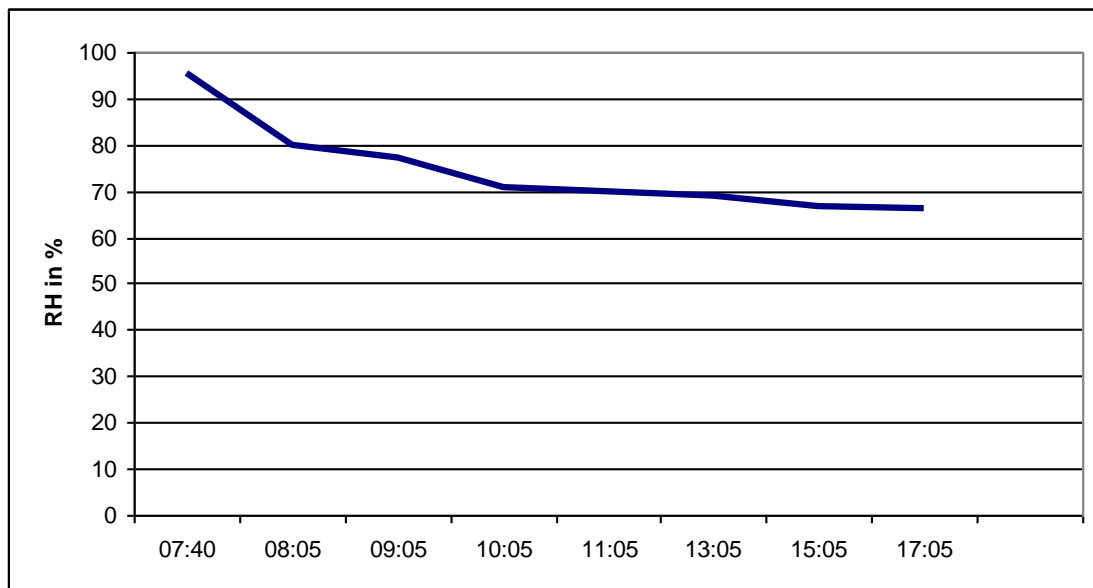

Fig. 9 Relative humidity in the growth chamber

TN 98.4.11	Preliminary trade-off for test plan and procedures
UGent	
<p>This document is confidential property of the MELiSSA partners and shall not be used, duplicated, modified or transmitted without their authorization</p> <p>Memorandum of Understanding 19071/05/NL/CP</p>	

2.2 Hydroponic system

2.2.1 Hydroponic system setup

Fig. 10 shows the schematic plan of the growth chamber with the placement of the eight gullies. The growth chamber has six rack positions with six lamp-modules on the top of each rack. Only four racks are used to place the gullies (racks in blue in Fig. 10). The distance between the rack and the lamp-module is 85 cm. The stainless steel gullies are one meter long, 19 cm wide and 6.5 cm high (see Fig. 11). They are placed on the rack with an inclination of 1 % (1 cm per 1 m). Four pieces of rockwool are placed in each gully to be the substrate of the plant. Each gully is independent from the other gullies and is connected to one pump and one tank for the nutrient solution. Each gully has a separate recirculating NFT system. The flow rate is 2 L/min at the beginning of the growth of the plant (minimal flow rate to produce a thin nutrient solution layer in the gully when rockwool is present, but not sufficient to cover the complete width of gully when rockwool is absent). Later in the growth of the plants, when the roots use the space around the rockwool and form barriers for the water flow, the nutrient solution delivery flow rate is decreased with the help of a tube clamp adjustment or by increasing the bypass flow. Since the nutrient film thickness is a critical parameter, it will be monitored weekly to assure the roots are not completely flooded or have an insufficient water supply; flow rate will be adjusted accordingly when needed. The root system of the plant is protected against light with black/white blackout plastic. All the tubes going from the tank to the pump and to the gully are covered with the same black/white blackout plastic to protect the nutrient solution from the light. The tanks are also protected against light and heat with a secondary layer of aluminium foil.

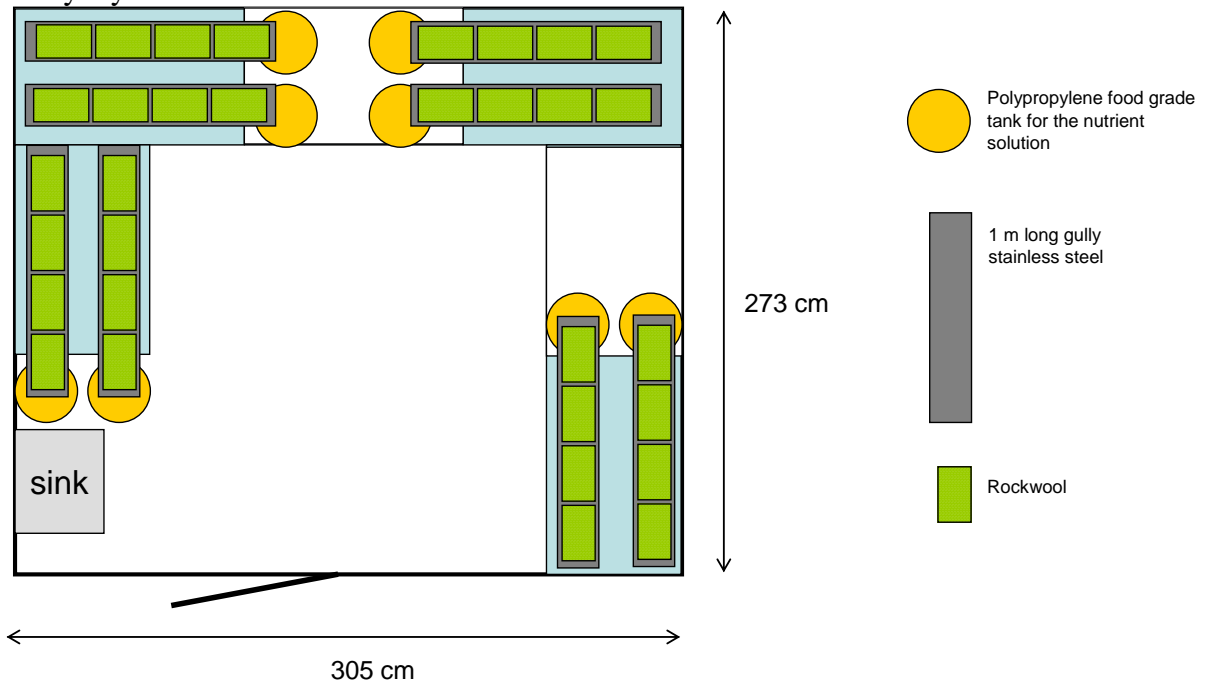

Fig. 10 Top view of the growth chamber with emplacement of the 8 gullies

TN 98.4.11	Preliminary trade-off for test plan and procedures
UGent	
This document is confidential property of the MELiSSA partners and shall not be used, duplicated, modified or transmitted without their authorization	
Memorandum of Understanding 19071/05/NL/CP	

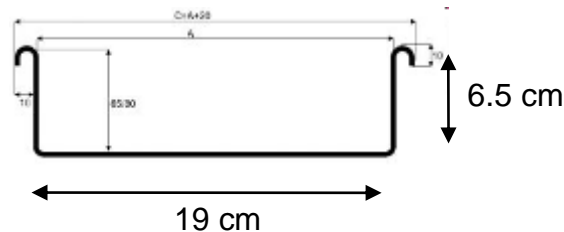

Fig. 11 Front cross section of a gully

2.2.2 Hydroponic system materials

- Polyurethane coated stainless steel gullies (1 m long, 19 cm wide and 6.5 cm high).
- Polyethylene plastic black/white film to cover the gullies and protect the roots.
- Polypropylene food grade tank for the nutrient solution (volume of 20 L).
- Transparent green silicone tubing (diameter 16 or 24 mm) connected to the pumps.
- Polypropylene connection for the tubes.
- Polyacetal y-connections for the bypass of the tube.
- Polyethylene tanks for the stock of nutrient solution.
- White elastic adhesive Zwaluw Hybrifix Super 7 (for the water tightness of the gullies and to protect the screw against oxidation).

2.2.3 Pumps

Pump EHEIM Universal 1260

Dimensions: 161 x 218 x 116 mm

Pump maximum rated flow rate: 3400 l/h (theoretical value with 0 m delivery head and no tubing attached; pump characteristics diagram specifies the theoretical minimum 0 l/h flow rate at the maximum delivery head of 3m). The setup delivery head equals 0.6m (height of tube entry into gully, pump located on floor).

To reduce the remaining high volumetric flow, two by-passes are placed at the pressure side of the pump (Fig. 12). This way it is possible to regulate the flow of nutrient solution in the target range 1-2 l/min, and to continuously mix the nutrient solution in the tank. The flow is continuous (constant flow rate).

Power consumption: 80 W

Despite their very high output, these pumps were chosen because the rotor magnet is coated. Smaller pumps of this type have uncoated magnets which might release small amounts of heavy metals to the nutrient solution.

TN 98.4.11	Preliminary trade-off for test plan and procedures
UGent	
This document is confidential property of the MELiSSA partners and shall not be used, duplicated, modified or transmitted without their authorization	
Memorandum of Understanding 19071/05/NL/CP	

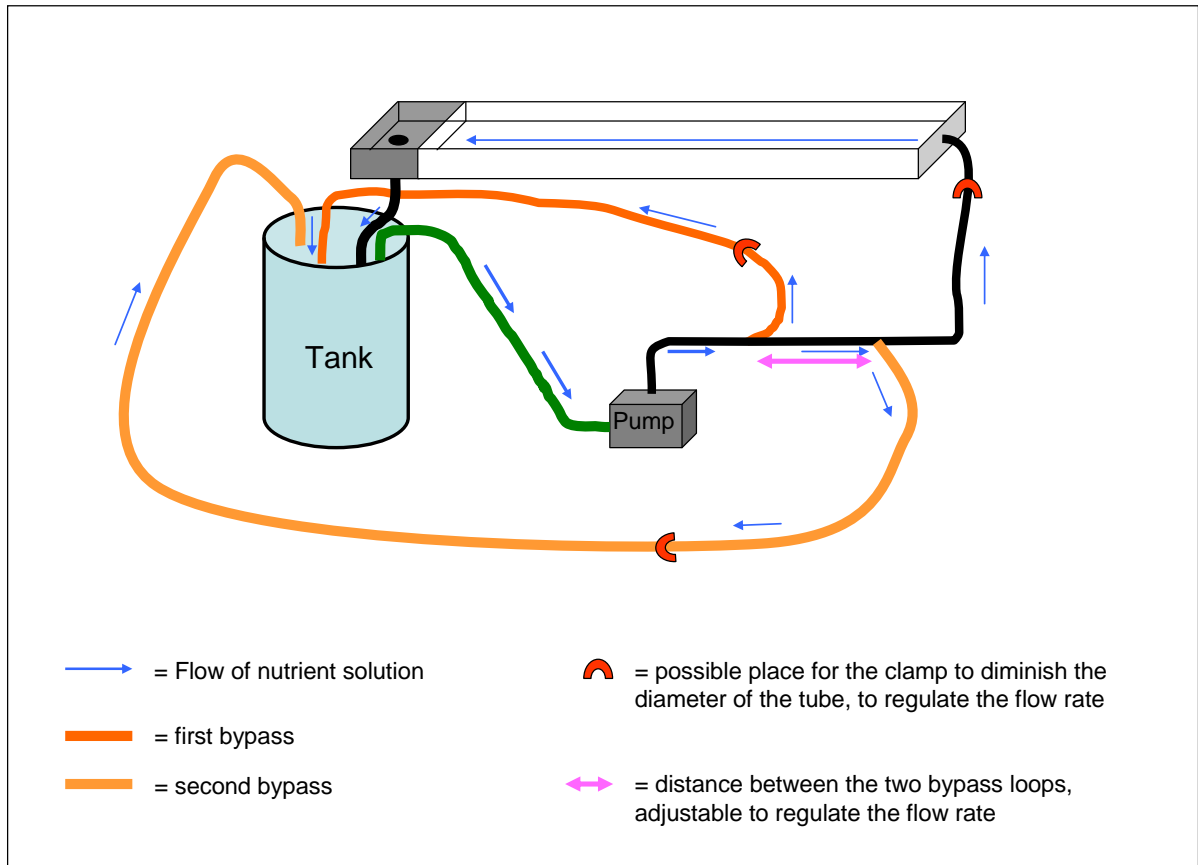

Fig. 12 Scheme of the hydroponic system

TN 98.4.11	Preliminary trade-off for test plan and procedures
UGent	
<p>This document is confidential property of the MELiSSA partners and shall not be used, duplicated, modified or transmitted without their authorization</p> <p>Memorandum of Understanding 19071/05/NL/CP</p>	

2.2.4 Substrate

Grodan Multiblocks (Grodan AO 25/40 10/10 W), blocks of 25x25x40 mm (40 mm high) fixed together in a plate, diameter of the holes 10/10 mm. The Grodan detachable plugs are conical in shape, and have space between them for root development, nutrient flow and gas exchange. The base of the plug is 16 X 16 mm. See Fig. 13.

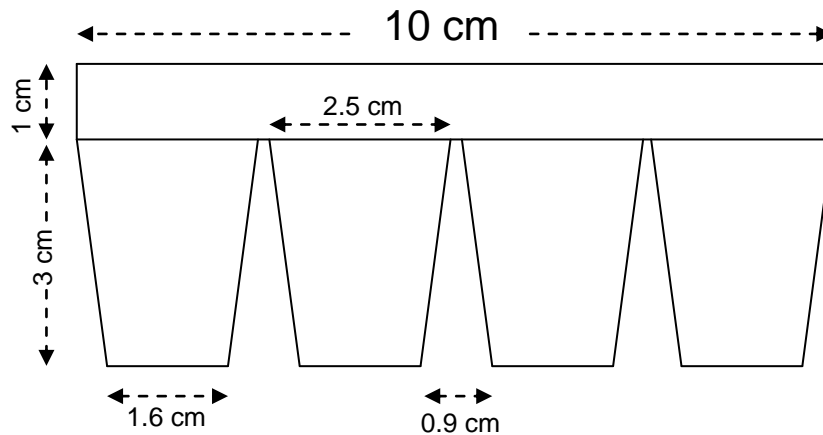

Fig. 13 Front view of the Grodan Plugs (piece of 10 cm)

Each sheet of rockwool is 15 x 22.5 cm (6 x 9 plugs). The weight of each piece was measured prior to seeding. The seedlings were placed in every second hole of the rockwool (see Fig. 18). Four pieces of rockwool were placed in the gully and named from a to d from the entry to the exit of the gully (see Fig. 14).

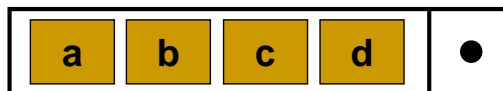

Fig. 14 Emplacement of the Rockwool pieces in the gully

2.2.5 Nutrient solution composition

The same nutrient solution as used by the University of Guelph (see the recipe below, Tab. 1) is applied. However Ni is added since it is an essential micronutrient for the plants (Welch 1995). The final Ni concentration is the same concentration as in the nutrient solution usually used to grow plants at the University of Bern (nutrient solution described in Hildbrand et al, 1994). See Tab. 1.

The start up nutrient solution is followed by a higher concentrated solution (Tab. 1) to replenish during growth in response to decreased EC level. Nutrient solution is completely changed every four weeks to reduce potential build up of salts or other phytotoxic compounds. Nutrient solution samples are taken at the beginning of each new solution change and at the end of the 4 week interval. The nutrient solution volume is 15 litres per tank.

TN 98.4.11	Preliminary trade-off for test plan and procedures
UGent	
This document is confidential property of the MELiSSA partners and shall not be used, duplicated, modified or transmitted without their authorization	
Memorandum of Understanding 19071/05/NL/CP	

Tab. 1 Nutrient solution recipe for start-up solution and replenish tank solution

	Final concentration for start up solution	Final concentration for replenish solution
Macronutrients		
Fe-EDTA Solution		
FeCl ₃ * 6H ₂ O	50 µM	134 µM
EDTA	47.6 µM	127.8 µM
KH ₂ PO ₄	0.5 mM	10 mM
KNO ₃	2.5 mM	46 mM
MgSO ₄ * 7H ₂ O	1 mM	10 mM
Ca(NO ₃) ₂ * 4H ₂ O	2.5 mM	12 mM
Micronutrients		
H ₃ BO ₃	7.1 µM	92.7 µM
MnCl ₂ * 4H ₂ O	7.3 µM	96.1 µM
ZnSO ₄ * 7H ₂ O	0.9 µM	12.4 µM
CuSO ₄ * 5H ₂ O	0.5 µM	6.7 µM
(NH ₄) ₆ Mo ₇ O ₂₄ * 4H ₂ O	0.0016 µM	0.02 µM
Ni(NO ₃) ₂ * 6H ₂ O	0.5 µM	6.7 µM

2.2.6 Hydroponic system sensor

The pH and electrical conductivity (EC) are checked manually with handheld meters once a week. The meters (Adwa pocket pH meter AD-100 and Adwa pocket EC meter AD-204) are calibrated each week with included calibration solution and checked once against a laboratory instrument.

EC: 1.2 mS (expected value, based on information from UoGuelph)

pH: 5.6 – 6.0 (expected value, based on information from UoGuelph)

2.2.7 Cooling system for the nutrient solution

From the pre-test experiment (see part 2.4 and Fig. 8) it was shown that the temperature of the nutrient solution was around 26 °C during the day. With an aluminium foil placed around the tank, the temperature was around 25.5 °C. Under these conditions, a cooling system for the nutrient solution is not needed. The temperature of the nutrient solution is measured by a DUAL-TEMP infrared-probe thermometer.

TN 98.4.11	Preliminary trade-off for test plan and procedures
UGent	
This document is confidential property of the MELiSSA partners and shall not be used, duplicated, modified or transmitted without their authorization	
Memorandum of Understanding 19071/05/NL/CP	

If later during the growth of the plants, the temperature of the nutrient solution increases, a cooling system may be installed. This cooling system is a Lauda Alpha Kältethermostat (461-0058PRA8) from VWR International AG, Lerzenstrasse 16/18, 8953 Dietikon, Switzerland. Oxygen solubility decreases with temperature; the risk of anaerobic conditions is however estimated to be low (high mixing rate by circulation pump, fast flow in the gully and the thin nutrient solution layer).

2.2.8 Gullies cleaning

The gullies are cleaned before the start-up with detergent and rinsed with deionised water. The system is then run for 24 hours with deionised water.

Between the plant culture, the gullies are cleaned with hot citric acid (when needed), rinsed with deionised water, disinfected with bleach NaOCl or peroxide 1% (limited duration of contact TBC) and rinsed again with deionised water. Afterwards the system is run for 24 hours with deionised water.

2.3 Test plan

2.3.1 Cultivar selected

The selected cultivars are the spring wheat Fiorina, CH Rubli, Greina and Aletsch. The list of characteristics (see Tab. 2) was established following the information on winter and spring bread wheat collected in the document “Liste recommandée des variétés de céréales pour la récolte 2009” (available at http://swissgranum.ch/pdf/LR2009_Cereale_F.pdf or through the UGent file servers) published by the research station Agroscope Changins-Wädenswil ACW (www.acw.admin.ch/), the research station Agroscope Reckenholz-Tänikon ART (www.art.admin.ch/) and swiss granum (www.swissgranum.ch/). Some quantitative data about yield, precocity of ear emergence, height of the plants, content of proteins, weight per 100 litres of grains and weight of 1000 grains were added in the list. This information was found in the report “Blé de printemps Sommerweizen 2007” (available at http://www.db-acw.admin.ch/pubs/ch_cha_08_pub_ble_printemps_resultats_f.pdf or through the UGent file servers) published by the research station Agroscope Changins-Wädenswil ACW and the research station Agroscope Reckenholz-Tänikon ART. The small differences in the qualitative and quantitative data are due to the fact that quantitative data were for the year 2007, while the qualitative data were from the year 2008. Differences may occur in the growth of the plants for the different year of cultivation.

TN 98.4.11	Preliminary trade-off for test plan and procedures
UGent	
This document is confidential property of the MELiSSA partners and shall not be used, duplicated, modified or transmitted without their authorization	
Memorandum of Understanding 19071/05/NL/CP	

Tab. 2 Characteristics of the spring wheat cultivars selected for the FC phase 1

Variety	Fiorina *	Aletsch	Greina*	CH Rubli	
Year of inscription	2001	2003	1994	2008	
Quality class	Top	1	1	1	
Yield in q/ha	good 44.5	middle 38.2	middle to weak 37.1	good 46.4	
Precocity of ear emergence ± days comparing to standard variety	mid-precocious 0.5	mid-precocious 1.6	precocious - 5.7	precocious - 2.3	
Height of the plants in cm	middle to short 81.9	middle 87.5	middle to short 70.8	middle 86.0	
Resistance to	lodging	good	good	good	good
	powdery mildew	good	good	middle	good
	yellow rust of wheat	very good	middle	middle	good
	brown rust of wheat	middle	middle	good	middle
	Septoria nodorum on the leaves	middle	middle	middle to weak	middle to good
	Septoria nodorum on the ear	middle	middle	middle to weak	middle
	Septoria tritici on the leaves	middle	middle	middle	middle
	fusariose on the ear	middle	middle to weak	middle to weak	middle to weak
	pre-harvest sprouting	middle to good	middle to good	middle to good	middle to good
Content of proteins in %	good 15.3	good 15.8	middle to good 15.4	good 15.7	
Quantity of gluten	middle to good	middle to good	good	middle to good	
Weight for 100 liters of grains in kg	middle 76.2	very good 79.4	very good 77.2	very good 79.9	
Weight of 1000 grains in g	middle 37.7	small 33.1	small 31.7	small 33	

* can be sown in autumn

2.3.2 Seeds treatment

In order to avoid potential contamination problems, the seeds are sterilized prior to seeding in the chamber by treating in 70% ethanol for 2 minutes followed by 20% commercial bleach for 10 minutes with gentle shaking and rinsed 5 times with sterile laboratory grade water.

Seeds are then germinated on wet filter paper (deionised water) in square plastic boxes with cover, in the growth chamber (germination in the dark). The recipient is first cleaned with detergent, well rinsed with deionised water, sprayed with ethanol and dried. Seeds are germinated for two (CH Rubli), three (Aletsch and Greina) or four (Fiorina) days. Germinated seeds are then selected for the same germination stage (when seed coat opens and stem and

TN 98.4.11	Preliminary trade-off for test plan and procedures
UGent	
This document is confidential property of the MELISSA partners and shall not be used, duplicated, modified or transmitted without their authorization	
Memorandum of Understanding 19071/05/NL/CP	

roots emerge, see Fig. 15) and are placed in the wet rockwool (see Fig. 16). This protocol minimizes root damage and bad positioning in the rockwool. One day after the transfer of the germinated seeds, the proper placement of the plants in the rockwool is checked.



Fig. 15 Developmental stage of the wheat grain selected for transfer to rockwool



Fig. 16 Grain of wheat in the hole of the rockwool

2.3.3 Plant cultural condition

Wheat is grown in 1 x 0.19 m stainless steel gullies in rockwool (Grodan AO 25/40 10/10W) using a recirculating nutrient film technique delivery system. Seeds are sown at a planting density of 60 seeds per gully (15 seeds per rockwool piece and four rockwool pieces per gully, see Fig. 18), two gullies per cultivar (Fig. 17). The distance between two plants is 5 cm and is comparable to the distance between plants of wheat growing in the field (Basler 2008). The four pieces of rockwool (15 cm x 22.5 cm) are placed in the gully so as to provide enough space for the nutrient solution to flow around the rockwool. A plastic black/white blackout cover with slits to accommodate the wheat is placed over the rockwool to minimize algae growth and reduce evaporation. The rockwool is rinsed with deionised water prior to use to remove particulate material from the substrate.

TN 98.4.11	Preliminary trade-off for test plan and procedures
UGent	
This document is confidential property of the MELiSSA partners and shall not be used, duplicated, modified or transmitted without their authorization	
Memorandum of Understanding 19071/05/NL/CP	

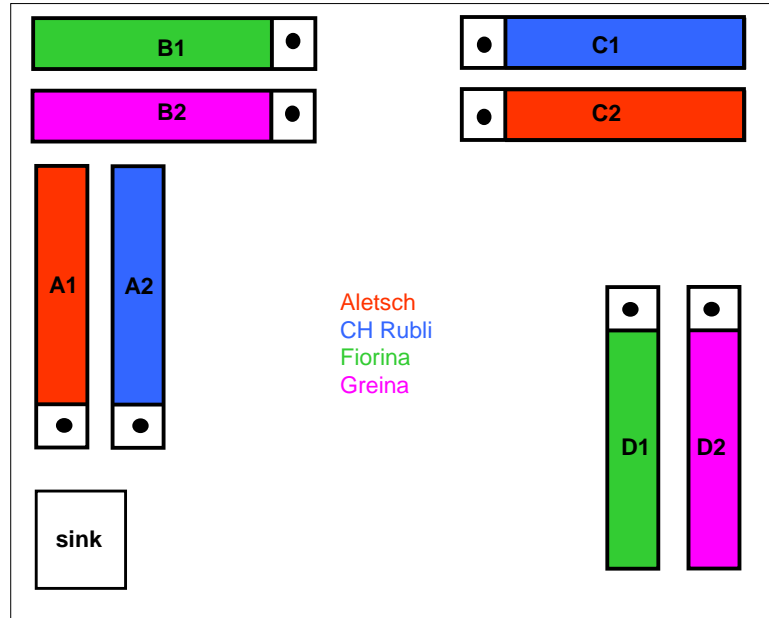

Fig. 17 Placement of the spring wheat cultivars in the growth chamber

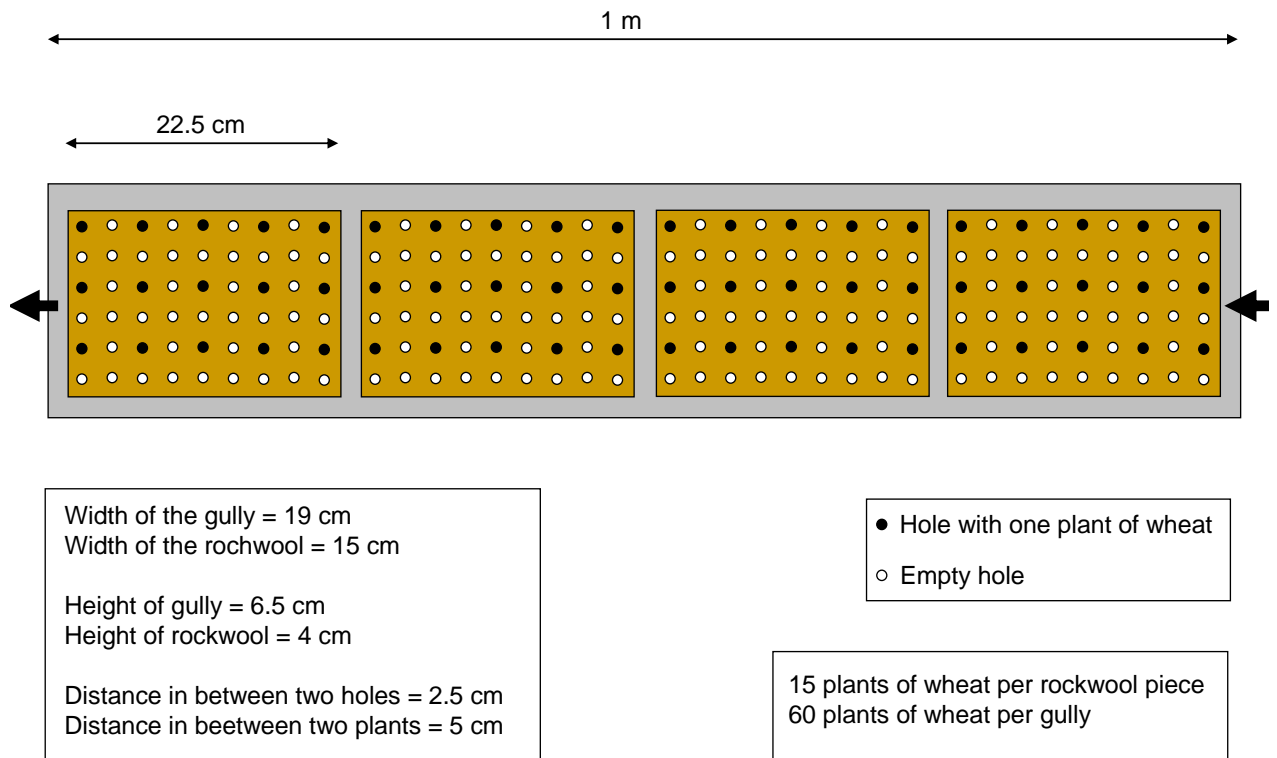

Fig. 18 Scheme of the gully and the Rockwool

TN 98.4.11	Preliminary trade-off for test plan and procedures
UGent	
This document is confidential property of the MELiSSA partners and shall not be used, duplicated, modified or transmitted without their authorization Memorandum of Understanding 19071/05/NL/CP	

2.3.4 Plant growth period

Seeds will be sterilized and placed in the growth chamber for germination on Monday 24 of August. Two days (CH Rubli), three days (Greina and Aletsch) and four days (Fiorina) after beginning of germination, the grains were ready for the transfer into the rockwool. The estimated completion date is December 2009.

2.3.5 Nutrient solution analysis

pH and EC are manually measured (Adwa pocket pH meter AD-100 and EC meter AD-204, gvz-rossat SA, Switzerland). Sampling of hydroponics solution is performed at the beginning and end of each 4 week nutrient solution interval and stored for AAS, photometric or reflectometric analyses.

2.3.5.1 Macronutrients: N P K Ca Mg S in the nutrient solution

- K, Ca, Mg measured by atomic absorption spectrophotometry (AAS)
- N measured by reflectometric method with analytical test strips (Reflectoquant Nitrate Test, 5-225 mg/L NO₃⁻, Merck, Germany) and handheld reflectometer (RQflex plus, Merck, Germany)
- P measured by photometric method using a phosphate reagent (100 mL ammonium heptamolybdate 5% + 100 mL ammonium vanadate 2.5% + 67 mL HNO₃ concentrated). (Stieger and Feller, 1994)
- S measured by photometric test, new method to be tested, kit of reagents (Spectroquant - Sulfate Test, 25-300 mg/L SO₄²⁻, Merck, Germany) and reflectometer (RQflex plus, Merck, Germany)

2.3.5.2 Micronutrients: Fe Mn Zn Cu Mo Cl Ni in the nutrient solution

- Fe, Zn, Cu, Mn measured by AAS
- Cl measured by photometric test (kit of reagents Spectroquant Chloride Test, 2.5-250 mg/L Cl⁻, Merck, Germany and photometer Spectroquant NOVA 60, Merck, Germany), new method to be tested and by reflectometric test (analytical test strips Reflectoquant Chloride Test, 0.05-1.00 g/L Cl⁻, Merck Germany and reflectometer RQflex plus, Merck, Germany), new method to be tested
- Ni measured by photometric test, new method to be tested (kit of solutions Spectroquant Nickel Test, 0.02-5.00 mg/L Ni, Merck, Germany and photometer Spectroquant NOVA 60, Merck, Germany)
- Mo measured by photometric test, new method to be tested (kit Spectroquant Molybdenum Cell Test, 0.02-1.00 mg/L Mo, Merck, Germany and photometer Spectroquant NOVA 60, Merck, Germany)

TN 98.4.11	Preliminary trade-off for test plan and procedures
UGent	
This document is confidential property of the MELiSSA partners and shall not be used, duplicated, modified or transmitted without their authorization	
Memorandum of Understanding 19071/05/NL/CP	

2.3.6 Kernel analysis

2.3.6.1 Macronutrients in the kernels

- K, Ca, Mg measured by atomic absorption spectrophotometry (AAS)
- The kernels are heated in an oven at 550°C for several hours. The ashes are solubilised in HCl. After mixing, deionised water is added. The sample solution is diluted with CsCl Suprapur in HCl (for K) and LaCl₃ in HCl (for Mg and Ca). (Stieger and Feller, 1994)
- P measured by photometric method using a phosphate reagent (100 mL ammonium heptamolybdate 5% + 100 mL ammonium vanadate 2.5% + 67 mL HNO₃ concentrated). (Stieger and Feller, 1994)

2.3.6.2 Micronutrients in the kernels

Fe, Mn, Zn, Cu measured by atomic absorption spectrophotometry (AAS)

The kernels are heated in an oven at 550°C for several hours. The ashes are solubilised in HCl. After mixing, deionised water is added. The sample solution is diluted with HCl. (Stieger and Feller, 1994; Zeller and Feller, 1999)

2.3.7 Food quality analysis

The food quality analysis is a task for ETHZ consultant Prof. Erich Windhab, who proposes to compare the harvested grains with grains grown in the field (e.g. seed material used for the experiment).

2.3.8 Plant development

Plant morphogenic development is assessed non-quantitatively by visual control. This allows determination of key developmental milestones such as appearance of leaves, initiation of flowering, and phytotoxicity symptoms (chlorosis, leaf cupping, tip burn, etc.).

One representative plant per Rockwool block of 15 plants (a-d) is followed to determine its height, number of tillers, number of leaves, number of ears and number of grains per ear.

The morphology (time-points of initiation) of the representative plant is followed for the stem elongation, ear emergence, anthesis, and ear yellowing. Anthesis is defined as the moment when the anthers release their pollen and is identifiable by the appearance of the stamen on the ear, see Fig. 19). The proper leaf senescence during grain ripening is checked.

TN 98.4.11	Preliminary trade-off for test plan and procedures
UGent	
This document is confidential property of the MELiSSA partners and shall not be used, duplicated, modified or transmitted without their authorization	
Memorandum of Understanding 19071/05/NL/CP	



Fig. 19 Ears of plant from the preliminary experiment. The stamens are visible.

2.3.9 Biomass data

Plant growth parameters to be measured after harvest are fresh weight and dry weight of roots (root dry weight is determined by the difference of the dry weight of the rockwool blocks before and after the growth period), kernels, and the remaining above ground material (stem and foliage), grain preprocessing debris (depending on processing approach at ETHZ).

2.3.10 Yield estimation

The estimated yield is 1-2 g grains per plant (estimation made with the results of the preliminary experiment, wheat grown in hydroponic pots). With 15 plants per block it may be approximately 25 g per block a-d. For the 60 plants per gully it may be 100 g grains per gully.

2.3.11 Timing of the measurements

The measurements of pH and electrical conductance of the nutrient solution, the CO₂ in the growth chamber, the air temperature at gully level, the temperature of the nutrient solution, the visual assessment for the plant development (see 2.3.8), the flow rate, the macro and micro-nutrient content in the kernels and the biomass are done following the information found in Tab. 3. When the nutrient film thickness is excessive (flooding the roots) or insufficient (parts of the gully bottom not covered by the film), nutrient flow rate will be adjusted.

TN 98.4.11	Preliminary trade-off for test plan and procedures
UGent	
This document is confidential property of the MELiSSA partners and shall not be used, duplicated, modified or transmitted without their authorization	
Memorandum of Understanding 19071/05/NL/CP	

Tab. 3 Timing of the measurements

Measurements	Timing
T, Relative humidity	Automatic
Chamber CO ₂ level	Once a week
Air temperature at gully level	Weekly min and max
Plant development	Once a week
Temperature of the nutrient solution	Once a week
EC Electrical conductance	Once a week (twice if necessary at full vegetative development stage)
pH	Once a week (twice if necessary at full vegetative development stage)
Flow rate	At start, after flow adjustment, at harvest
Nutrient solution (nutrient content)	Every 4 weeks, before and after solution exchange
Biomass	After the harvest
Kernels nutrient content	After the harvest

2.3.12 Reference of the measuring devices

pH

Adwa pocket pH meter AD-100, gvz-rossat SA, Switzerland
Range: -2.0-16.0 pH, resolution: 0.1 pH, accuracy ± 0.1 pH

EC

Adwa pocket EC meter AD-204, gvz-rossat SA, Switzerland
Range: 0.00-19.99 mS/cm, resolution: 0.01 mS/cm, accuracy: ± 2 % full scale

Light intensity

Quantum Meter, Photosynthetic Photon Flux ($\mu\text{mol m}^{-2} \text{s}^{-1}$), sun and electric calibration, Spectrum Technologies, Inc.
Range: 0-2000 $\mu\text{mol m}^{-2} \text{s}^{-1}$ (full sunlight) ± 5 %

CO₂

Environmental Instruments, Anagas CD 95, Geotechnical Instruments, Leamington Spa, UK
Range 0-2500ppm; accuracy ± 150 ppm in the range 0-1000 ppm. Measuring flow 350ml/min.

Hygrometers

- Hygrometer (mechanical thermohygrographs plotting relative humidity and temperature), Feingeratebau K. Fischer GmbH, Germany
- Hygrometer (mechanical hair hygrometer indicating relative humidity), TFA, Germany

Thermometer

DUAL-TEMP infrared-probe thermometer, TFA, Germany
Infrared: range: -33 - +220°C accuracy: ± 2 °C
Probe: range: -55 - +330 °C accuracy: ± 1 °C

TN 98.4.11	Preliminary trade-off for test plan and procedures
UGent	
This document is confidential property of the MELiSSA partners and shall not be used, duplicated, modified or transmitted without their authorization Memorandum of Understanding 19071/05/NL/CP	

2.4 Preliminary testing

A preliminary experiment was carried out to test if the hydroponic system was running well. The grains of the four selected spring wheat cultivars (Aletsch, Fiorina, Greina and CH Rubli) were germinated on the 7 of July for 2 days in the dark, on wet paper. On July 9th, the germinated grains were placed in the Rockwool blocks following the scheme of Fig. 18, but one cultivar per piece of Rockwool. The plants were cultivated in the gully until 20 of August without problem. After three weeks of growth, the flow rate was decrease with a clamp placed on the nutrient solution delivery tube. The nutrient solution used in the pre-test was not the same nutrient solution that is used for the FC phase 1 project, but a nutrient solution used for several years at the University of Bern to grow wheat plants in hydroponic pots (nutrient solution described in Hildbrand et al, 1994).



Fig. 20 Pre-test with the four spring wheat cultivars

2.5 References

- Basler S. 2008. Versuchsbericht. Landwirtschaftliches Zentrum.
- Hildbrand M, Fischer A, Feller U. 1994. Protein catabolism in bean leaf discs: accumulation of a soluble fragment of ribulose-1,5-bisphosphate carboxylase/oxygenase under oxygen deficiency. *Journal of Experimental Botany* 45: 1197-1204
- Stieger PA, Feller U. 1994. Nutrient accumulation and translocation in maturing wheat plants grown on waterlogged soil. *Plant and Soil* 160: 87-95
- Welch RM, 1995. Micronutrient nutrition of plants. *Critical Review in Plant Sciences*, 14(1): 49-82
- Zeller S, Feller U. 1999. Long-distance transport of cobalt and nickel in maturing wheat. *European Journal of Agronomy* 10: 91-98

TN 98.4.11	Preliminary trade-off for test plan and procedures
UGent	
This document is confidential property of the MELiSSA partners and shall not be used, duplicated, modified or transmitted without their authorization	
Memorandum of Understanding 19071/05/NL/CP	

3 Durum Wheat (UGuelph)

The Controlled Environment Systems Facility (CES) provides a complete research venue suitable for measurement of plant growth, gas exchange, volatile organic compound (VOC) evolution, and nutrient remediation in a precisely controlled environment. The facility is comprised of 24 sealed environment chambers including 14 variable pressure (hypobaric) plant growth chambers capable of sustaining a vacuum. CES's personnel have extensive experience in the fields of plant physiology, environment analysis and sensor technology.

The SEC2 walk-in plant growth chambers (aka 'blue boxes') are capable of a high degree of closure and are dedicated specifically to canopy-scale lighting studies, trace hydrocarbon analyses, nutrient recycling studies, and control/manipulation of abiotic growth factors in sealed environment plant production. These sophisticated chambers represent the current technical venue for large scale plant studies related to space life sciences at the University of Guelph.



Fig. 21 View on the SEC2 growth chambers

TN 98.4.11	Preliminary trade-off for test plan and procedures
UGent	
<p>This document is confidential property of the MELiSSA partners and shall not be used, duplicated, modified or transmitted without their authorization</p> <p>Memorandum of Understanding 19071/05/NL/CP</p>	

3.1 Growth Chamber Specifications

3.1.1 Dimensions

- Volume = 29 m³ (430 ft³) (4.5 m x 2.8 m x 2.3 m) per chamber
- Plant growing area = 5 m² (54 ft²) (2 m x 2.5 m) per chamber

3.1.2 Construction materials used

- Stainless steel 316 (walls, floor, valves, plumbing)
- Glass (roof)
- Teflon (tubing, gas expansion bladders)
- Polypropylene (tubing, valves)
- Heresite (oxidation barrier on fans, heat exchangers, motor parts)
- Viton (O-rings, solenoid seats)
- Silicone sealant (DOW-Corning RTV 732) and silicone grease

3.1.3 Analysers

- LiCor LI6262 Gas Analyser for CO₂/H₂O vapour
- California Analytical Instruments Oxygen Analyser (model 100P)
- Gas Chromatograph/Mass Spectrometer (HP-5890/HP-5971)
- Gas Chromatograph (SRI 8610C) for ethylene analysis
- Dionex DX500 HPLC Ion Chromatograph (off-line nutrient analysis)

3.1.4 Lighting

- 9x600 Watt high pressure sodium + 6x400 Watt metal halide per chamber
- Light level (PPFD): 365 to 845 μmol m⁻² second⁻¹ PAR at medium plant height and 370-664 μmol m⁻² second⁻¹ PAR at bench height (see Fig. 22 to Fig. 24)

TN 98.4.11	Preliminary trade-off for test plan and procedures
UGent	
This document is confidential property of the MELiSSA partners and shall not be used, duplicated, modified or transmitted without their authorization	
Memorandum of Understanding 19071/05/NL/CP	

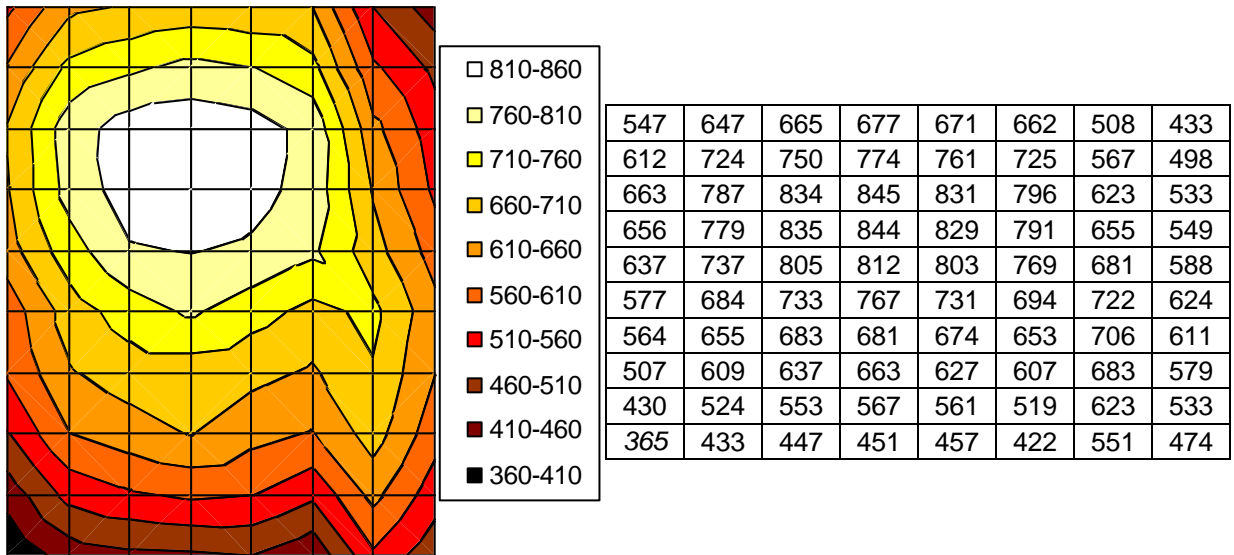

Fig. 22 Photon flux in $\mu\text{mol}/\text{m}^2\text{s}$ measured 135 cm from the floor

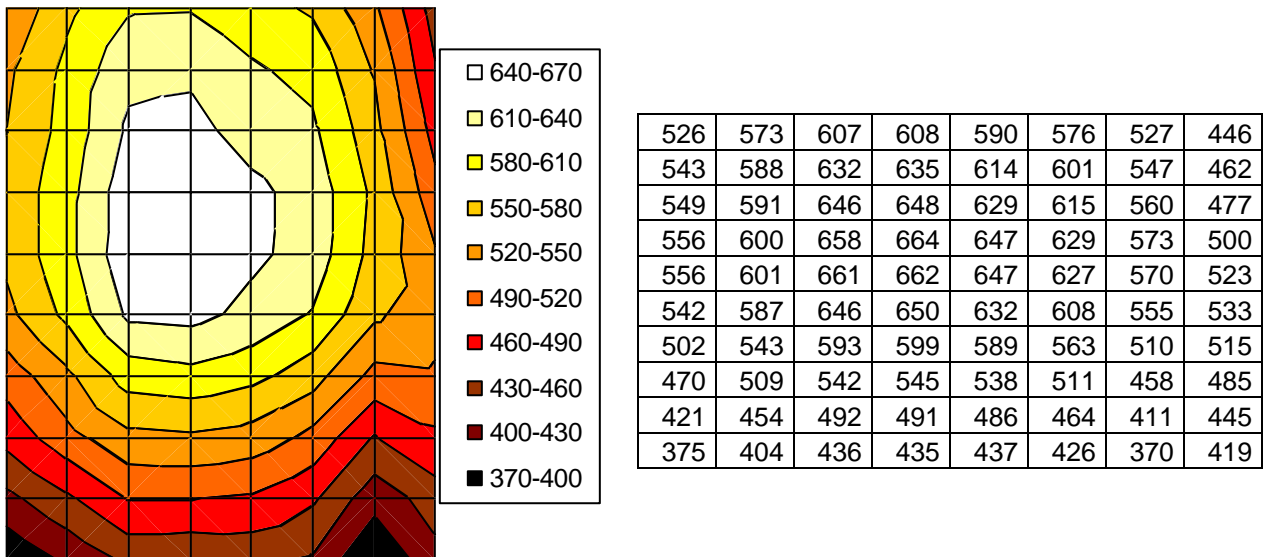

Fig. 23 Photon flux in $\mu\text{mol}/\text{m}^2\text{s}$ measured 100 cm from the floor

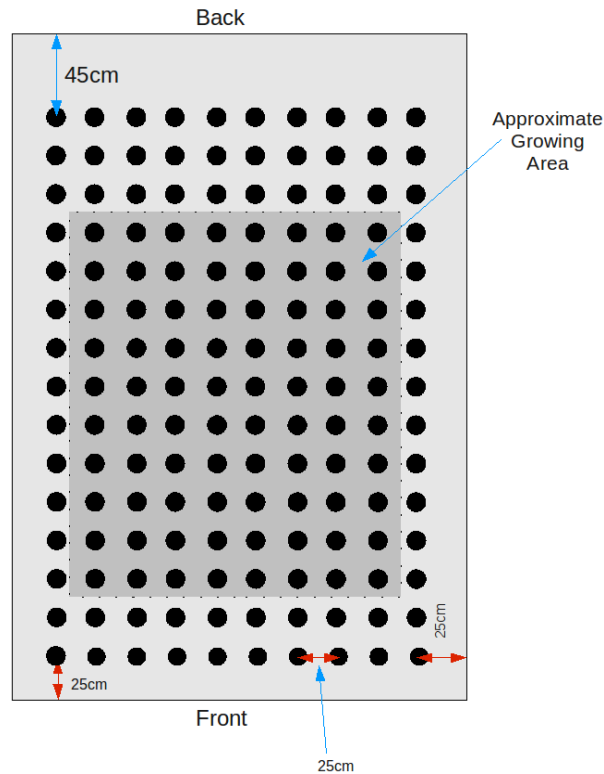

Fig. 24 Measurement locations for light mapping (not to scale)

3.1.5 *Hydroponic system sensors*

- Electrical conductivity (two per chamber)
- pH (two per chamber)

3.1.6 *Chamber sensors*

- Air humidity sensors (two per chamber)
- Air temperature sensors (two per chamber)
- Root zone temperature sensors (four per chamber)
- Light PAR sensor: LiCor Quantum Sensor (one per chamber)

3.1.7 *Environment control*

- Temperature (10 to 40 C) + 0.2 C
- CO₂ concentration (ambient to 3000 ppm) + 10 ppm
- O₂ concentration (ambient)
- Relative humidity (50% to 95%) + 5%

TN 98.4.11	Preliminary trade-off for test plan and procedures
UGent	
This document is confidential property of the MELiSSA partners and shall not be used, duplicated, modified or transmitted without their authorization	
Memorandum of Understanding 19071/05/NL/CP	

3.1.8 Control system

The data acquisition and control system consists of MS-DOS (Version 6.22, Microsoft Corporation) based computer software (L.W. Anderson Software Consultant) that commands an Allen-Bradley PLC-5/10 controller mounted on a 1771-A3B1 12 slot backplane. The 1771 input/output (I/O) system includes three 16 channel 12-bit A/D modules (1771-IFE), one 8 channel 12 bit analogue output module (1771-OFE2), one 16 channel digital output module (1771-OBD), and three 16 channel digital input modules (1771-IBD). The external tank solution level sensor utilizes a float contactor coupled to a control unit with relay outputs which control a gravity return solenoid valve (ASCO, Brantford, Ontario; see Fig. 27, NC2). Alarm warnings from the Lander DACS (various parameters - temperature too high/low, lighting fault, etc) are captured by a Linux computer and upon receipt, automated email messages are sent to operations personnel.

3.1.9 Air handling

SEC2 chambers air is conditioned for temperature and humidity and is re-circulated inside the chambers. Externally supplied chilled water and hot water are circulated through sealed and "Heresite" coated (baked oxidation barrier) heat exchange coils mounted in an internal plenum at the rear of each chamber. Condensate from the chilled water coil is measured and collected in the hydroponics nutrient reservoir. Heresite coated fans and fan motors with silicone covered wiring are also mounted in the plenum and distribute the air through stainless steel ducts with baked enamel louvers. Modulated hot and chilled water valves effect temperature and dehumidification control of the aerial environment.

3.1.10 Nutrient delivery system

The nutrient requirements for the plants are supplied in a hydroponics medium and stored in an external 100 L tank and an internal 200 L tank. The solution is pumped into polypropylene tubing to the head of sloped stainless steel troughs. The five 2.5 metre long troughs are designed to accommodate a variety of root media as a substrate for the hydroponics solution. These include glass beads, Rockwool, Lecca (expanded clay particles), silica sand, etc. Gravity provides the return of the solution to the internal reservoir, which in turn supplies the external delivery tank through a solenoid valve connected to a level sensor within the external tank. The condition of the solution with respect to pH and electrical conductivity is monitored and adjusted continuously through measured injections of acid, base and/or various nutrient mixes.

3.1.11 Pressure compensation

Each SEC2 chamber is fitted with ten 200 litre double sealed Teflon® liners (Now Technologies Inc., Minneapolis, MN) manifolded on a 50 mm diameter stainless steel tube which is connected through the rear wall of the chamber. This provides a total expansion volume potential of 2.0 m³ or ±1.0 m³. Given the 29 m³ internal volume of the chamber, this represents about 7% (±3.5%) volume expansion/contraction in response to temperature fluctuations inside the chamber. The total temperature range influencing gas volume in the chamber represented by this capacity is about 20 Kelvin degrees (±10 degrees).

TN 98.4.11	Preliminary trade-off for test plan and procedures
UGent	
<p style="text-align: center;">This document is confidential property of the MELiSSA partners and shall not be used, duplicated, modified or transmitted without their authorization Memorandum of Understanding 19071/05/NL/CP</p>	

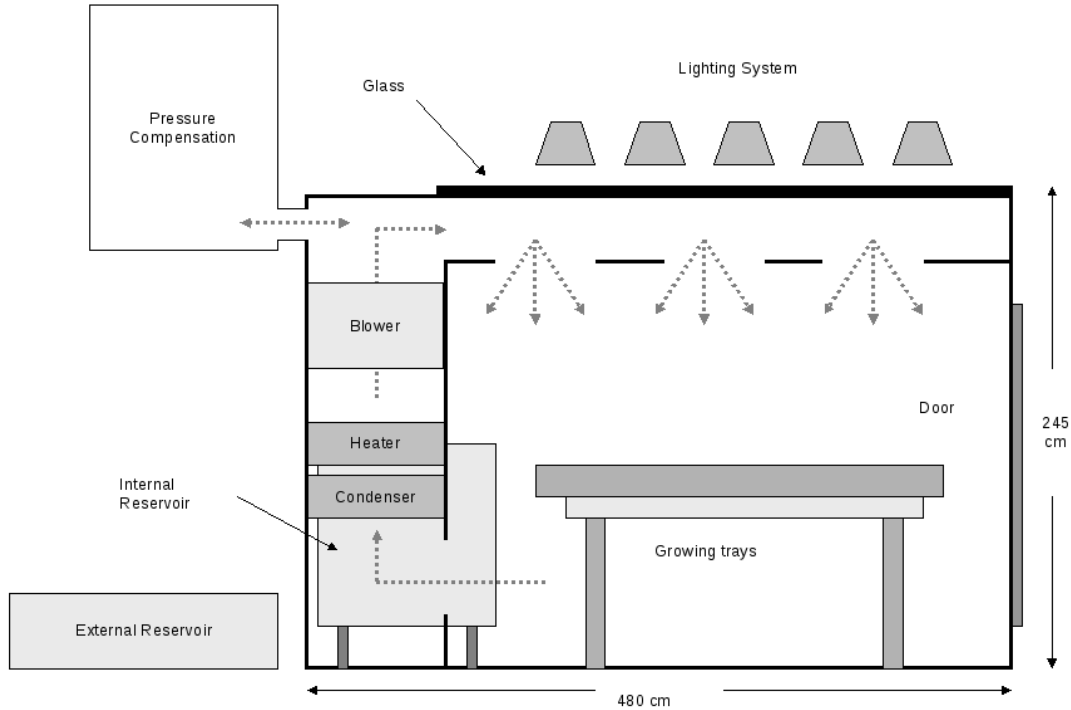

Fig. 25 Side schematic of one of the UoG sealed environment plant growth chambers

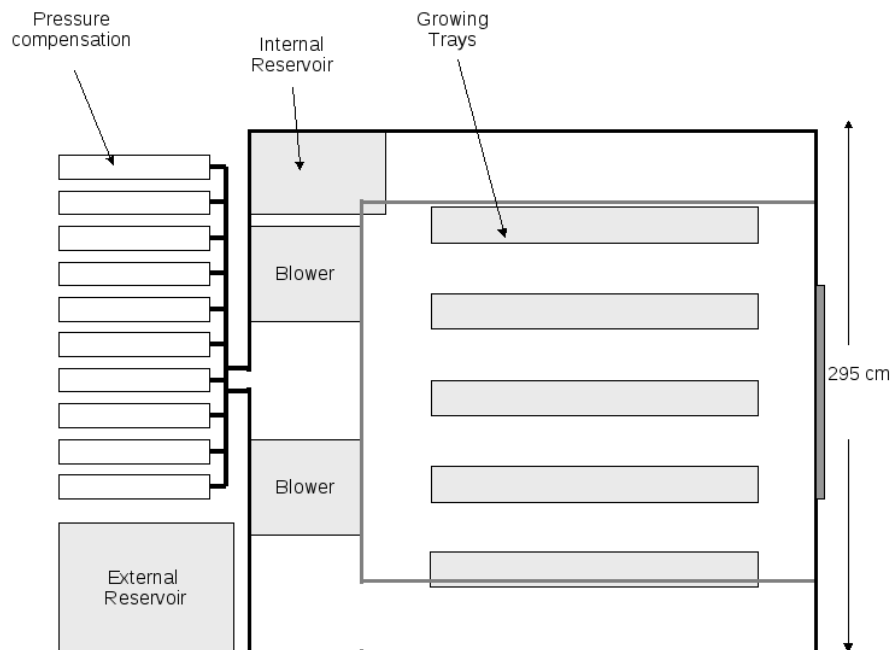

Fig. 26 Top view schematic showing hydroponic tray location.

TN 98.4.11	Preliminary trade-off for test plan and procedures
UGent	
This document is confidential property of the MELiSSA partners and shall not be used, duplicated, modified or transmitted without their authorization	
Memorandum of Understanding 19071/05/NL/CP	

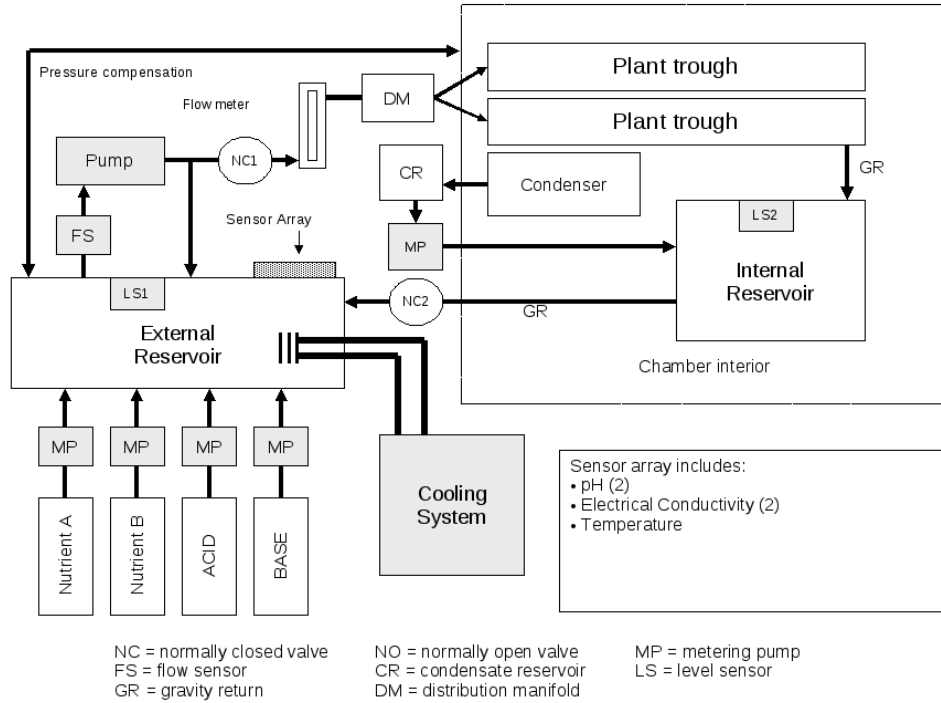

Fig. 27 Nutrient system schematic

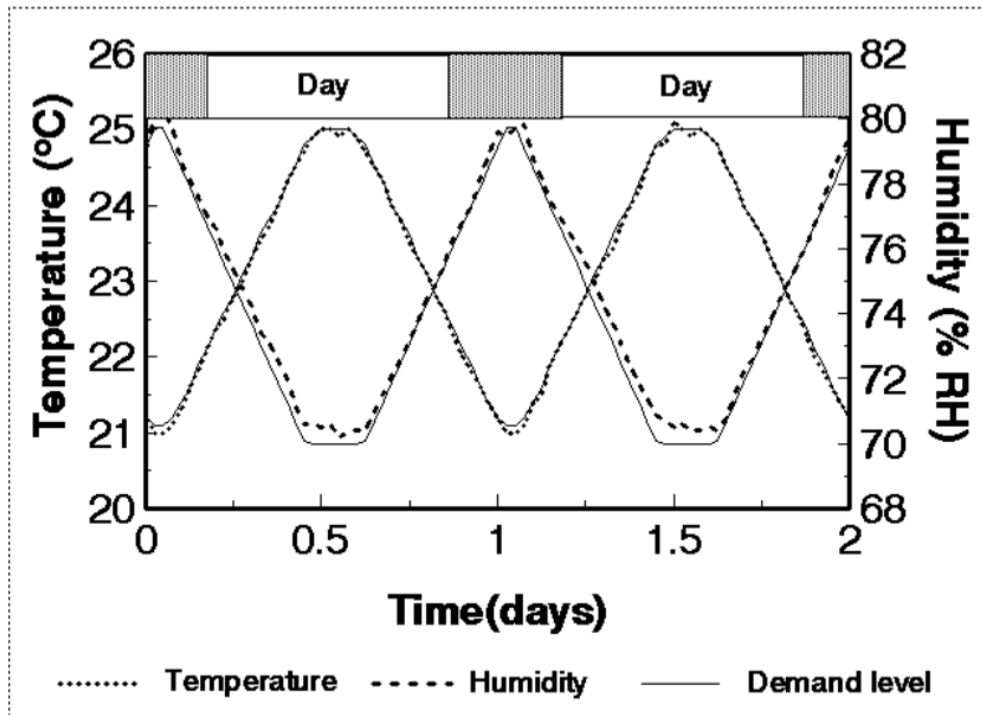

Fig. 28 Temperature and Humidity control in a 56 day old soybean crop.

TN 98.4.11	Preliminary trade-off for test plan and procedures
UGent	
This document is confidential property of the MELISSA partners and shall not be used, duplicated, modified or transmitted without their authorization	
Memorandum of Understanding 19071/05/NL/CP	

3.2 Test plan

3.2.1 Objective

The objectives of this study are as follows:

1. Monitor CO₂ assimilation/evolution
2. Monitor evapotranspiration
3. Monitor hydroponic nutrient system parameters (pH, EC, selected ions)
4. Monitor ethylene evolution
5. Evaluate growth parameters
6. Produce wheat kernels for further processing

3.2.2 Growing period

The study period refers to the time between initiation and completion of analysis. The study schedule may be changed during this period depending on schedules, priorities, and earlier results. The wheat varieties to be used in this experiment are Avonlea and Strongfield, each with a growth period of approximately 102 days.

Estimated Starting Dates:	Avonlea	July 6, 2009
	Strongfield	July 13, 2009
	Commander	February 8, 2010
	Eurostar	February 15, 2010

Estimated Completion Date: Approximately 120 days after start date

3.2.3 Crop growth procedures

Plant cultural conditions: Wheat is grown in 2.45 x .017 m stainless steel troughs in rockwool (Grodan AO 36/40 6/15W) using a recirculating nutrient film technique delivery system. There is a total of 5 troughs per chamber. Seeds are sown at a planting density of 135 seeds per trough split into three pads of 45 seeds (Fig. 29). A plastic black/white blackout cover with slits to accommodate the wheat is placed over the rockwool to minimize algae growth and reduce evaporation rates. A modified half-strength Hoagland's solution is used (Tab. 4). The rockwool is rinsed with deionised water prior to use to remove particulate material from the substrate.

TN 98.4.11	Preliminary trade-off for test plan and procedures
UGent	
<p>This document is confidential property of the MELiSSA partners and shall not be used, duplicated, modified or transmitted without their authorization</p> <p>Memorandum of Understanding 19071/05/NL/CP</p>	

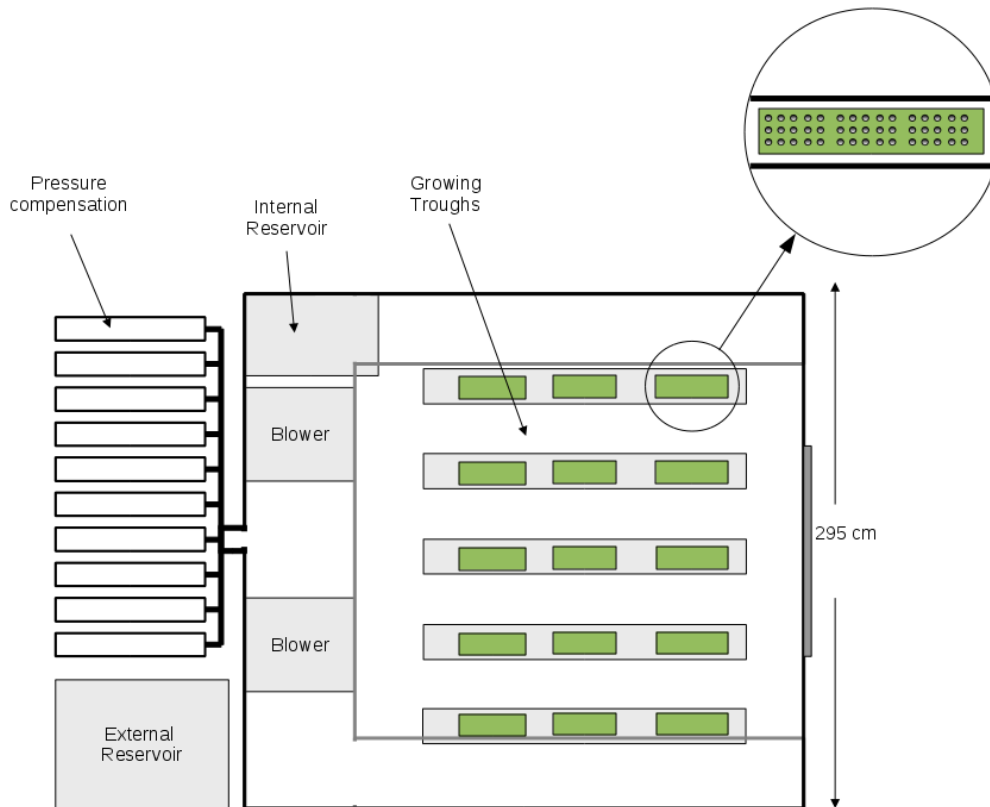

Fig. 29 Setup of troughs and plant positioning within the growth chamber

Solution pH is automatically adjusted by the control system to 5.8 +/- 0.2 with additions of dilute acid (nitric acid @ 0.5 M HNO₃) or base (potassium hydroxide @ 0.5M KOH). The Solution electrical conductivity is monitored and automatically adjusted by the control system to 1.2 mS with the modified stock solution (Tab. 4).

Nutrient solution is completely changed every four weeks to reduce potential build up of salts or other phytotoxic compounds.

TN 98.4.11	Preliminary trade-off for test plan and procedures
UGent	
<p>This document is confidential property of the MELiSSA partners and shall not be used, duplicated, modified or transmitted without their authorization Memorandum of Understanding 19071/05/NL/CP</p>	

Tab. 4 Nutrient solution recipe for 150 L start-up and 10L replenish tank solution

MACROS					
Formula	F.W.	g/L	Stock concentration	For 150L start up (1/2 HOAG)	For 10L replenishment container
1. Fe-EDTA Solution FeCl3 * 6H2O	270.3g	2.42	8.96mM	840ml	150ml
EDTA	292.2g	2.49	8.52mM		
2. KH2PO4	136.09g	136.09	1M	75ml	100ml
3. KNO3	101.1 g	101.1	1M	375ml	460ml
4. MgSO4 * 7H2O	246.48g	246.48	1M	150ml	100ml
5. Mixed micros (see part 1 and 2 below)		see below	Varies	150ml	130ml
6. Ca(NO3)2 * 4H2O	236.1 g	236.1	1M	375ml	120ml
7. Water				148.035L	8.94L
<ol style="list-style-type: none"> Mix each individual macro above in separate labelled carboys found in the Harvest Lab Prepare the mixed Micros (#6) as shown below. Add desired amount of Macro #1 - #6 to either 150 L or 10L replenish tanks - amounts specified for each listed in table above 					
MIXED MICROS (For #5 in Recipe Above)					
PART 1 - Mix each micronutrient separately as shown below					
Nutrient	F.W.	g/500 ml	Stock concentration	SEPARATE MICRONUTRIENT STOCK SOLUTIONS	
H3BO3	61.83g	14.7	0.4560M	Weigh out amts in highlighted column into individual 500 ml bottles and add 500 mL deionised water	
MnCl2 * 4H2O	197.9g	36.61	0.37M		
ZnSO4 * 7H2O	287.54g	9.2	0.064M		
CuSO4 * 5H2O	249.68g	6.50	0.052M		
(NH4)6Mo7O24 * 2H2O	1235.86g	0.10	1.01mM		
PART 2 - Prepare mixed micro solution by combining micro stocks (part 1) into 8L Carboy					
Nutrient	Separate stock concentration	ml for 8L carboy	Final concentration	Measure amts in highlighted column from the individual micro bottles above.	
H3BO3	0.4560M	120	7.13mM	Mix all in a single 8 L Carboy Bring to 8 L with 7440 mL of deionised water	
MnCl2 * 4H2O	0.37M	160	7.40mM		
ZnSO4 * 7H2O	0.064M	120	0.96mM		
CuSO4 * 5H2O	0.052M	80	0.52mM		
(NH4)6Mo7O24 * 2H2O	1.01mM	80	0.01mM		
TN 98.4.11	Preliminary trade-off for test plan and procedures				
UGent					
This document is confidential property of the MELISSA partners and shall not be used, duplicated, modified or transmitted without their authorization					
Memorandum of Understanding 19071/05/NL/CP					

Seed treatment: In order to avoid potential contamination problems, the seeds are sterilized prior to seeding in the chamber by treating in 70% ethanol for 2 minutes followed by 20% commercial bleach for 20 minutes with gentle shaking and rinsed 3 times with sterile laboratory grade water.

Environmental parameters: In each chamber, lighting is provided by nine 600 Watt High Pressure Sodium (HPS) and six 400 Watt Metal Halide (MH) lamps cycled to provide a 16-h light/8-h dark photoperiod. Air temperature is isothermal at 23°C (Mackowiak, Owens and Hinkle, 1989). CO₂ is maintained at concentration of 1200 µmol mol⁻¹ (partial pressure of 0.12 kPa), and relative humidity is set to 60% RH for the duration of crop growth. Once the crop has reached physiological maturity, the demand humidity is set to 0% in order to accelerate the drying process.

3.2.4 Sampling and analysis

Environment: Profiles of chamber atmospheric temperature, humidity (VPD), CO₂, and O₂ data are recorded at one minute intervals for the duration of this experiment. The only exception is that oxygen sampling shares one analyzer between the two chambers, with alternating two hour sampling intervals.

Nutrient solution: pH and EC are automatically measured and adjusted on a daily basis by the control system. Sampling of hydroponics solution is performed at the beginning and end of each 4 week nutrient solution interval and submitted for HPLC analysis at the end of the experiment (see 3.2.5 and 3.3). The following ions are analyzed: N, P, K, Ca, Mg, S, Fe, Mn, Zn, Cu, Mo, Cl, B.

Ethylene: Air samples are monitored for ethylene through GC analysis at the CESRF laboratory every standard working day through the atmosphere sampling ports. Ethylene is sampled starting the first day after closure, and continue until harvest.

Biomass data: Plant growth parameters to be measured at the end of the growth period are dry weight of roots, kernels, and the remaining above ground material. Data is collected on a per pad basis for the entire chamber.

Edible biomass data: A single composite sample from each cultivar is tested for nutrient content (carbon, nitrogen, phosphorus, potassium, calcium and magnesium) and proximate composition including proteins, lipids, carbohydrates, and gluten index.

3.2.5 Analytical methods

Ethylene: Air samples from each chamber are taken, and a subsample is passed through the 1.0 mL sample loop of an SRI 8610C (SRI Instruments Inc., Menlo Park, California, USA) gas chromatograph (GC) equipped with a flame ionization detector (FID) and 30 metre 0.53mm ID

TN 98.4.11	Preliminary trade-off for test plan and procedures
UGent	
This document is confidential property of the MELiSSA partners and shall not be used, duplicated, modified or transmitted without their authorization	
Memorandum of Understanding 19071/05/NL/CP	

Supel-Q Plot capillary column (Supelco Inc). The GC is controlled by PeakSimple chromatography software (SRI Instruments Inc.). Calibration is carried out daily with a standard of known concentration. The detection limit for ethylene is 5 parts per billion (ppb) with a signal to noise ratio of 1 to 5. A cut-off minimum detection limit (MDL) of 10 ppb is employed for these experiments.

Nutrient solution analysis: Solution samples are analysed using a Dionex HPLC Model DX-120 (Sunnyvale, CA, USA) for ions of interest.

Wheat analysis procedures:

Day of harvest – harvesting per pad:

1. The average height of each pad is measured in centimetres with a meter stick.
2. Next, the stems of the plants in the pad are cut with scissors or shears to detach the stalks from the rockwool cubes.
3. Each of the heads are cut and separated from the stalks, and the number of heads are counted and recorded. The heads and chaff are put into r size 14 brown paper bags.
4. All straw material is placed into paper yard bags.
5. After each pad is harvested, the Rockwool masses and root tissue is removed, trimmed and placed with the rockwool into size 20 brown paper bags.
6. The three sets of bags, seeds and heads, straw, and roots, are placed into the drying room for 7 - 14 days, with the tops open.
7. Once dry, the bags are cooled down to room temperature and each bag and its contents is weighed and recorded.
8. Each bag is then placed into plastic bags for storage and to seal out moisture.

Threshing per pad:

1. By pad, heads are hand rolled to expose the seeds then the top layer of chaff can be disposed of. The rest of the chaff and seeds are placed into a container of water wherein the chaff floats on top and the seeds sink to the bottom
2. Separation of seeds is achieved by decanting the water and the chaff
3. Seeds are extracted from the container, patted dry with paper towel, placed into size 2 brown paper bags and put into the drying room for two days
4. Seeds are then cooled to room temperature, weighed, and placed in a single resealable plastic bag to provide a combined total sample.
5. Subsamples are removed and submitted for local analysis (Tab. 5) and the remainder is shipped to UNapoli for further analysis.

Tab. 5 Sample requirements

Laboratory	Parameters	Amount of Sample Required
<i>SEEDS</i>		
Soil and Nutrients Lab	%C, N, P, K, Ca, Mg	~1.5 grams of each cultivar
Agri-Food Lab	Proximate analysis	~15 grams of each cultivar
Cereal Research Centre	Gluten index	~ 10 grams of each cultivar

TN 98.4.11	Preliminary trade-off for test plan and procedures
UGent	
This document is confidential property of the MELiSSA partners and shall not be used, duplicated, modified or transmitted without their authorization	
Memorandum of Understanding 19071/05/NL/CP	

3.3 References

Total carbon and total nitrogen:

Official Methods of Analysis of AOAC International, 16th Edition (1997), AOAC International, Arlington, VA.

Sheldrick, B.H. 1986. Test of the Leco CHN-600 Determinator for soil carbon and nitrogen analysis. Can. J. Soil Sci. 66(3):543-545

Sweeney, Rose A. 1989. Generic combustion method for determination of crude protein in feeds: Collaborative Study. J. Assoc. Off. Anal. Chem. 72: 770-774.

McGeehan, S.L. and D.V. Naylor. 1988. Automated instrumental analysis of carbon and nitrogen in plant and soil samples. Commun. Soil Sci. Plant Anal. 19:493

Proximate analysis:

Official Methods of Analysis of AOAC International, 16th Edition (1997), AOAC International, Arlington, VA.

NO₃-N:

Keeney, D.R. and D.W. Nelson. 1982. Nitrogen - inorganic forms. p. 643-687. In: A.L. Page, et al. (ed.). Methods of Soil Analysis: Part 2. Agronomy Monogr. 9. 2nd ed. ASA and SSSA, Madison, WI.

Plant minerals (excluding N):

Isaac, R.A. and W.C. Johnson. 1975. Collaborative study of wet and dry ashing techniques for the elemental analysis of plant tissue by atomic absorption spectrophotometry. J. Assoc. Off. Anal. Chem. 58: 436-440.

Havlin, J.L. and P.N. Soltanpour. 1989. A nitric acid and plant digest method for use with inductively coupled plasma spectrometry. Commun. Soil Sci. Plant Anal. 14:969-980.

General:

CL Mackowiak, LP Owens, and CR Hinkle, 1989, Continuous Hydroponic Wheat Production Using A Recirculating System , NASA Technical Memorandum TM 102784

TN 98.4.11	Preliminary trade-off for test plan and procedures
UGent	
<p>This document is confidential property of the MELiSSA partners and shall not be used, duplicated, modified or transmitted without their authorization</p> <p>Memorandum of Understanding 19071/05/NL/CP</p>	

4 Potato

Given the particularities of potato culture, especially the induction and monitoring of the tuberisation process, the performance of the 4 selected cultivars is followed up at 2 different locations (UGent and UCL) with a maximum of characterisation methods.

UGent and UCL setup and plant growth environmental settings are harmonised as much as possible, given the different characteristics of the available plant growth facilities. Nutrient solution composition and hydroponic cultural practices overview are provided by a company specialised in seed potato production: HZPC (Hettema and De ZPC (Zaai- en Pootgoed Coöperatie)), as a consultant to UGent.

The analysis plan includes the measurement of the same set of basic plant growth environmental parameters, albeit with different methodology as determined by the control/logging functionality of each plant growth facility. Each lab's specific expertise is reflected by additional techniques included in the respective analysis plans.

Potato (UGent)

The Ghent University's workbench demonstrator is positioned in a walk-in chamber with precise environment control (Fig. 30).



Fig. 30 Growth chamber with equipment installed

TN 98.4.11	Preliminary trade-off for test plan and procedures
UGent	
<p>This document is confidential property of the MELiSSA partners and shall not be used, duplicated, modified or transmitted without their authorization Memorandum of Understanding 19071/05/NL/CP</p>	

4.1 Growth chamber specifications

4.1.1 Dimensions

The chamber measures 3m in length, 1.5m in width, and 2m in height (9m³). The plant growing area consists of four 0.5m wide and 1.70m long shelves (Fig. 31) which can each hold one 1.70m gully providing a total growing area of 3.4m² (0.5m x 1.7m x 4). Two gullies with a length of 1.7 m and two of 1.65 m are used. All gullies are 16 cm wide and 9.5 cm high.

4.1.2 Lighting

Each gully has the same illumination system and thus the same light distribution. Four 146 cm long dimmable units of eight fluorescent lamps (Master TL-D reflex Super 80 58W / 840 from Philips: <http://www.philips.be>) illuminate the four 170 cm shelves, with a distance between the lights and the shelves of 66.5 cm. The method of photoperiod control is ON/OFF: a 16 h day and an 8 h night period (Tab. 6). Based on available info, these conditions should guarantee a successful tuber induction in all cultivars selected. Longer light periods can be inhibitory for tuber induction.

Tab. 6 Photoperiod and light range

Light PPF	250-400 $\mu\text{mol m}^{-2} \text{s}^{-1}$
Photoperiod	16 h light, 8 h dark

Not all plants in each gully receive the same amount of light. At both ends of the gullies a slightly lower intensity is apparent. In Tab. 7, the light flux as a function of plant position is shown. The first values correspond to the average light flux at rack level. The second values represent the flux at 30cm below the light tube, which is the maximal plant height.

A mapping of the light intensities was made at different levels (Fig. 32):

- 52.5 cm from the lights: that corresponds to the height the in acclimated and elongated in-vitro plants reach at the start of the test when they are fixed to the horizontal support.
- 46.5 cm from the lights: this is an intermediate growth height.
- 30 cm from the lights: this is the maximum height the plants can reach, without being affected by the movements of the monitoring robot. Under nominal conditions (determined by adjustable nitrogen dosage) the plants do not grow higher. In case of taller growth, the plants will be pruned to the appropriate size.

Light intensity values are shown in Fig. 33, spectral quality is assumed constant (Fig. 34).

Tab. 7 Light flux in function of the plant position

PPF* $\mu\text{mol m}^{-2} \text{s}^{-1}$	Suboptimal (84-280)				Optimal (188-320)								Suboptimal (90-290)			
	1	2	3	4	5	6	7	8	9	10	11	12	13	14	15	16
Plant position (each 10cm)																

*PPF: Photosynthetic Photon Flux

TN 98.4.11	Preliminary trade-off for test plan and procedures
UGent	
This document is confidential property of the MELiSSA partners and shall not be used, duplicated, modified or transmitted without their authorization	
Memorandum of Understanding 19071/05/NL/CP	

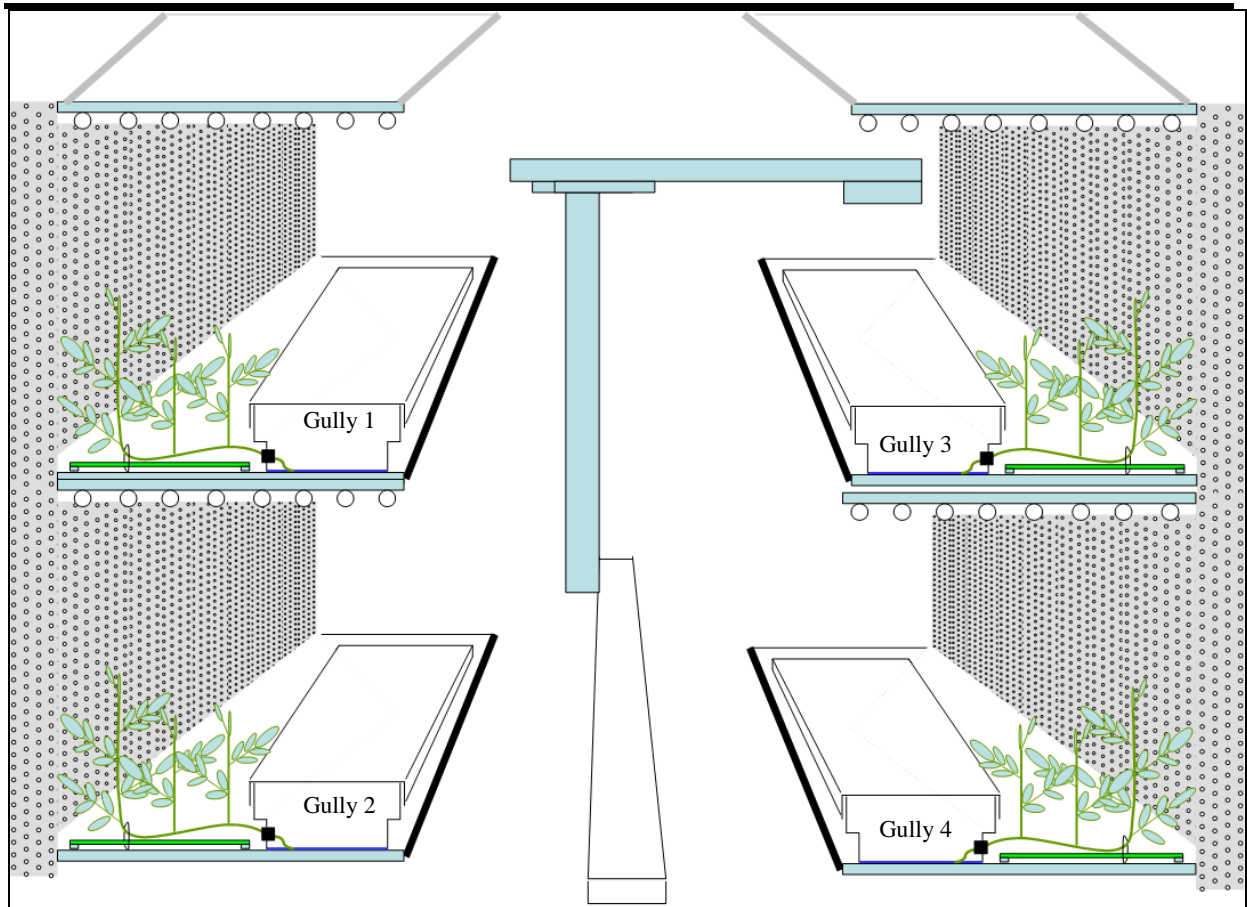

Fig. 31 Schema of the growth chamber with gullies numbered from 1 to 4.

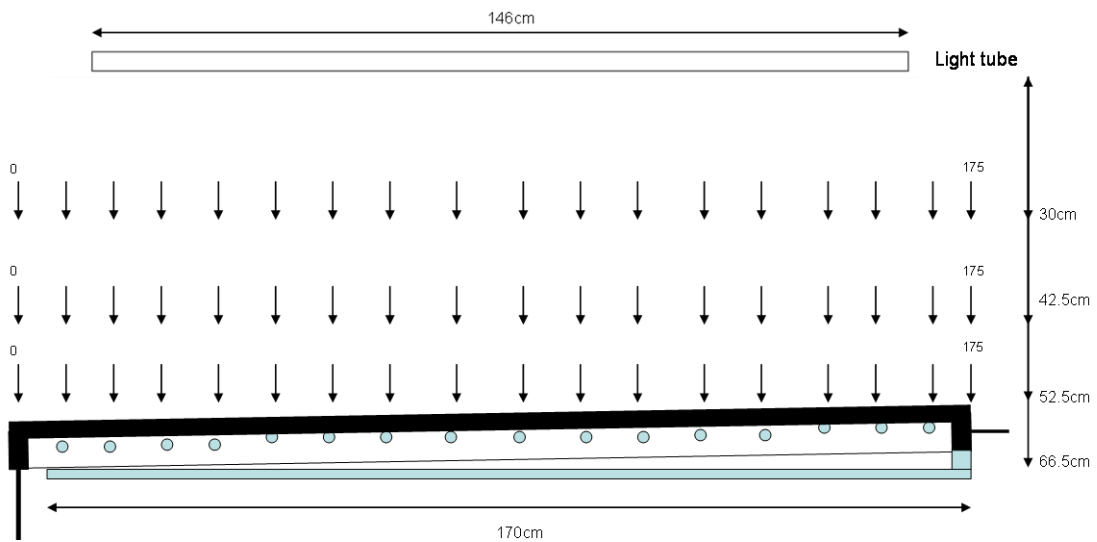

Fig. 32 Point of light intensity measurement above the rack

TN 98.4.11	Preliminary trade-off for test plan and procedures
UGent	
<p>This document is confidential property of the MELiSSA partners and shall not be used, duplicated, modified or transmitted without their authorization</p> <p>Memorandum of Understanding 19071/05/NL/CP</p>	

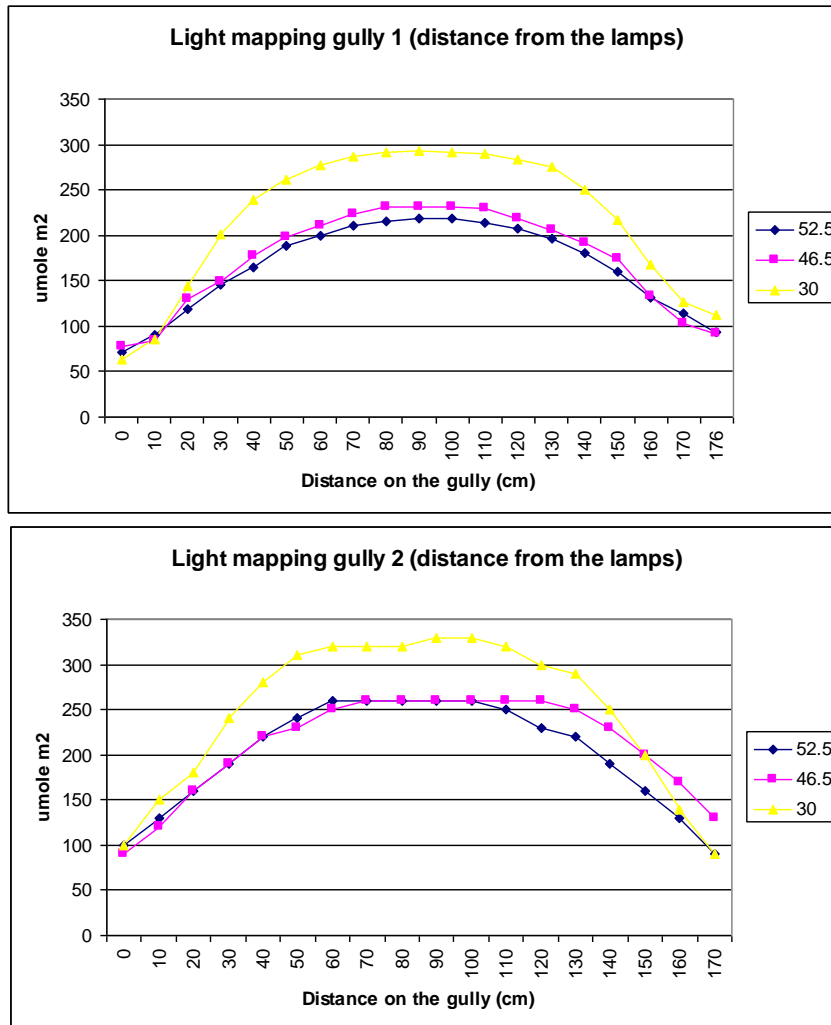

Fig. 33 Light flux mapping above rack 1 (higher) and 2 (lower).

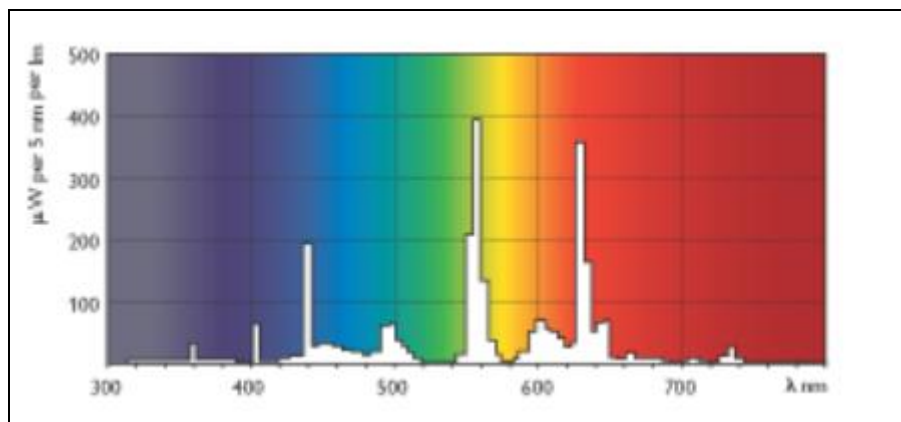

Fig. 34 Spectrum of the light tube MASTER TL-D Reflex 58W/840

TN 98.4.11	Preliminary trade-off for test plan and procedures
UGent	
This document is confidential property of the MELiSSA partners and shall not be used, duplicated, modified or transmitted without their authorization	
Memorandum of Understanding 19071/05/NL/CP	

4.1.3 Environment control

4.1.3.1 Air temperature and relative humidity

Air temperature and humidity are controlled by a Siemens RMU730 PLC (cascade PID control, using two RTD (LG-Ni 1000) temperature sensors for respectively cooled input air and chamber exit air). Air relative humidity is increased with a steam humidifier (Carel UR010HL001) and lowered by condensation in the chamber air/chilled water (provided by a Daikin EUWA5KZW1 unit) heat exchanger. Ventilation is manually adjustable with a Variable Frequency Drive (Hitachi L200 075HF EF). The air ventilation layout consists of air input and output through opposite metallic perforated walls.

For online measurement of air temperature and relative humidity, the Vaisala Humicap® temperature and humidity transmitter is used (HMT333; <http://www.vaisala.com/businessareas/instruments/products/humidity/fixed/hmt330>).

Technical specifications for relative humidity:

Measurement range: 0-100 % RH
 Accuracy at +20 °C: ± 1.0 % RH (0-90 % RH)
 ± 1.7 % RH (90-100 % RH)
 Sensor: Vaisala Humicap® 180

Technical specifications for temperature:

Measurement range: -40 to+80 °C
 Accuracy at +20 °C: ± 0.2 °C
 Sensor: PT100 RTD 1/3 Class B IEC 751

Data signal output: RS-232

- PLC Programmable Logic Controller RMU730 (<http://www.siemens.com/index.jsp>) with ACS7 operating/logging software. Cooling and heating by PI control of modulated 3-way chilled water valve and heating resistances, and humidification by steam supply.
- Air ventilation maximum 8000 m3/h – adjustable with Variable Frequency Drive Hitachi L200 075HF EF (<http://www.hitachi-ies.co.jp/pdf/catalog/SM-E242R.pdf>). Ventilation unit with chilled water coil, electrical resistances and filter section.
- Steam humidifier Carel UR010HL001 (http://www.carel.com/carelcom/web/eng/catalogo/prodotto_dett.jsp?id_gamma=34&id_tipologia=9&id_prodotto=67)
- Chilled water primary circuit Chiller Daikin EUWA5KZW1 (http://global.daikin.com/global/our_product)
- Perforated walls from RMIG (<http://www.rmig.com/>):
 - Material: stainless steel
 - Diameter perforation: 5 mm
 - Distance between perforations: 8 mm (centre to centre)
 - Open area due to perforation: 35%
 - Distance to real walls: 0.24 m
 - Distance to backside of air-duct (an inclined plate ensures an even distribution of air flow along the vertical): 0.24 m at air entry from ceiling of room
0.04 m at bottom of room
 - Dimensions perforated wall input: 3 x 2 m (total wall surface)

TN 98.4.11	Preliminary trade-off for test plan and procedures
UGent	
This document is confidential property of the MELiSSA partners and shall not be used, duplicated, modified or transmitted without their authorization Memorandum of Understanding 19071/05/NL/CP	

Dimensions perforated wall output: 2 x 2 m (total wall surface)

4.1.3.2 Settings and error limits

Light range:	0-400 $\mu\text{mol m}^{-2} \text{s}^{-1}$ PAR
Temperature range:	20 to 30 °C
Error temperature:	± 0.2 °C
Humidity range:	60 to 80 % RH
Error humidity:	± 5 % RH
Fresh air supply:	0 to 2 $\text{m}^3 \text{h}^{-1}$
Air circulation:	3000 to 8000 $\text{m}^3 \text{h}^{-1}$

The ventilation of the cooling system is continuous. The temperature of the air and relative humidity are measured by Vaisala Humicap® and Delta T sensors. Setpoint for temperature is 20 degrees, the setpoint for relative humidity is 70 % RH (corresponding to a VPD of 0.82 kPa at 20 degrees). The O₂ concentration is ambient and measured with a PP Systems electrochemical cell every 10 minutes (OP-1 Probe). CO₂ concentration is measured with a WMA-4 IRGA. The measuring takes place every ten minutes at chamber level, with the air intake tube located in the culture room. The measuring range is 0-2000 ppm (Tab. 8). A safety thermostat turns off the lamps automatically in case of temperature increase due to cooling system failures (setting at 25°C). All the conditions of the growth chamber (turning on/off the lamps, temperature, humidity, ventilation speed) are logged.

Temperature fluctuations are within 0.4 degrees during the day, on average there is 0.5 degree temperature difference between the racks at both sides of the room (Fig. 35).

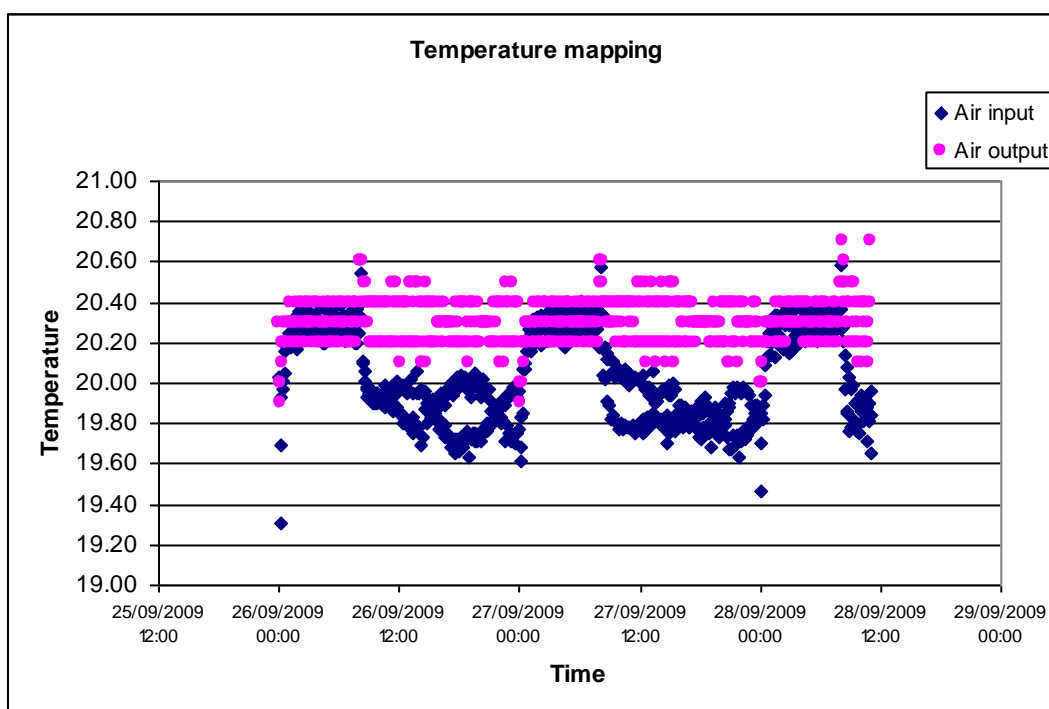

Fig. 35 Air input (rack 1) and output (rack 3) temperature, dark period from 0 to 8 AM

TN 98.4.11	Preliminary trade-off for test plan and procedures
UGent	
This document is confidential property of the MELiSSA partners and shall not be used, duplicated, modified or transmitted without their authorization	
Memorandum of Understanding 19071/05/NL/CP	

Along the length of the rack a heterogeneity in temperature of about 1 degree was measured during the day period (Fig. 36), which does not correlate with the larger expected light system heat load in the centre of the rack. Hence a difference in air flow speed is assumed. Humidity increases upon the day/night transition (Fig. 37), due to the transient change in T.

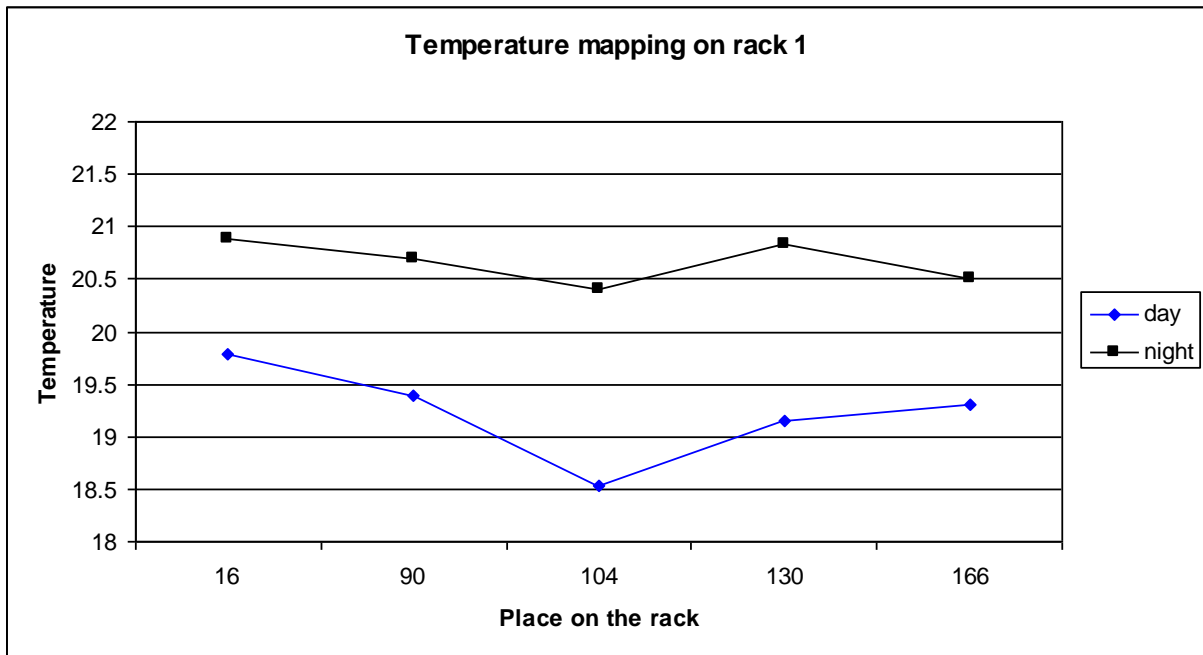

Fig. 36 Day and night temperature mapping on rack 1

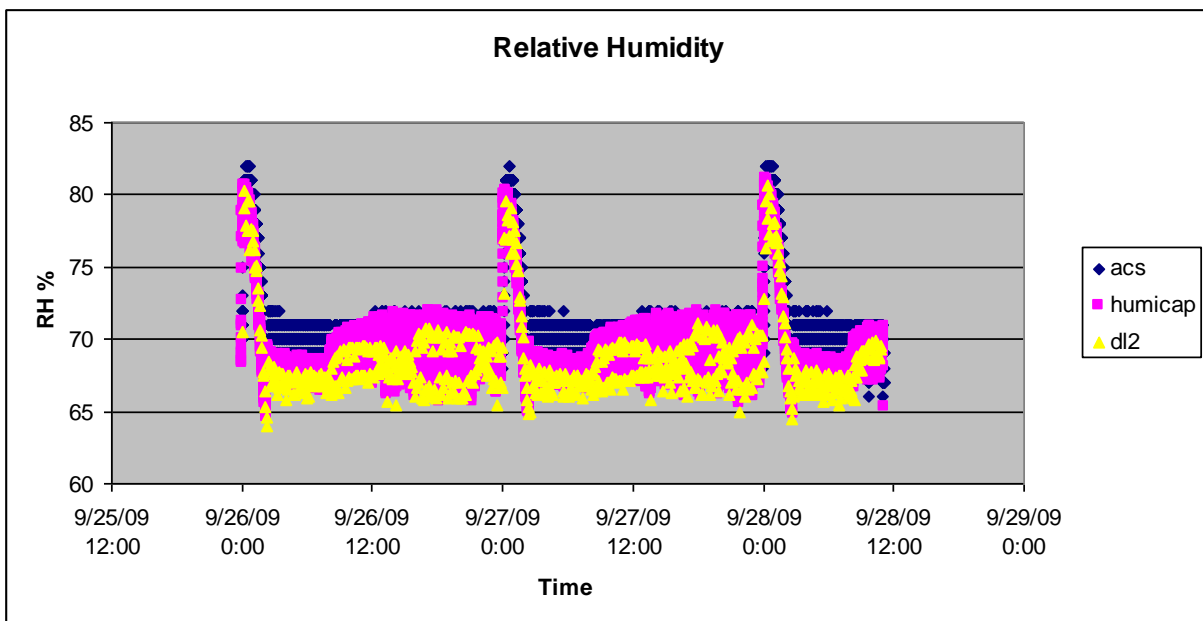

Fig. 37 Relative humidity in the growth chamber – dark period 0 – 8 AM

TN 98.4.11	Preliminary trade-off for test plan and procedures
UGent	
This document is confidential property of the MELiSSA partners and shall not be used, duplicated, modified or transmitted without their authorization	
Memorandum of Understanding 19071/05/NL/CP	

Tab. 8 Sensors for online measurement of required environmental parameters

Parameter	Sensor
In air:	
CO ₂	WMA-4 IRGA from PP Systems measuring range 0-2000ppm ADC2250 IRGA dual channel with 2 plant or leaf cuvettes
O ₂	Electo-chemical cell measuring range 0-30% attached to WMA-4 from PP Systems (OP-1 Probe)
Light	Quantum Sensor SKP 215 (Skye instruments)
Temperature	Vaisala Humicap®, Delta T
Temperature nutrient solution	NTC-10K
Humidity	Vaisala Humicap®, Delta T
Ethylene	ETD-300 from Sensor Sense connected to the cuvettes
Weight of gully (whole plant)	Load cells (MP40 from Sartorius) for shelf 2

4.2 Hydroponic system

4.2.1 Hydroponic system explanation

Gullies were obtained from JBHydroponics (Maasdijk, NL). They are made of PU coated stainless steel and are 170 cm long, 16 cm wide at the bottom (25 cm at the top) and 9.5 cm high. On one side, 2 cm holes are pierced every 10 cm at 1.2 cm from the bottom of the gully. In these holes plastic tubes are fixed (2 cm long and 2 cm diameter) with their extremities covered by black flexible plastic, in which a cross was cut to allow the plant stem to pass through (for general view see Fig. 38). This setup is used to minimize light in the gully in order to prevent greening of tubers.

Gullies are positioned with a downward angle of 5%, nutrient flow is adjusted to 2 L/min, and the gullies drain by gravity. Gullies are connected to separate tanks (LxBxH 40x20x20cm) made from food grade HDPE by means of submerged NJ1700 (AquariumSystems NewJet 1700 L/h) pumps. Each gully has a separate nutrient solution circuit (Fig. 39). EC, pH, and nutritive solution level are measured by sensors and automatically readjusted with 3 stock solution tanks (pH with H₃PO₄ or KOH tank by manual switching, EC with K₂SO₄ and KH₂PO₄,) and injected via three Hanna Instruments blackstone BL 1,5 injection pumps (output 1.5 L/h, 13 bar). Tank level is adjusted with distilled water. Upon detection of a decrease in water level by the level sensor, a fixed amount of 1 liter of water is transferred through the action of an air compressor connected to a submerged 1l recipient fitted with an auto-fill valve (opening and allowing water in when the compressor is off, closing when the compressor is on). The water handling system with its associated electronic control is displayed in Fig. 40.

The nutrient solution temperature is kept constant with a cooling system (TECO TR5 160W, Teco, Ravenna, Italy). The cooling capacity is sufficient for two tanks. The MJ1000 pump (1000 L/h, AquariumSystems MaxiJet) circulates the cooled water through a coil made of silicon tubing positioned in each nutrient solution tank.

TN 98.4.11	Preliminary trade-off for test plan and procedures
UGent	
This document is confidential property of the MELiSSA partners and shall not be used, duplicated, modified or transmitted without their authorization	
Memorandum of Understanding 19071/05/NL/CP	

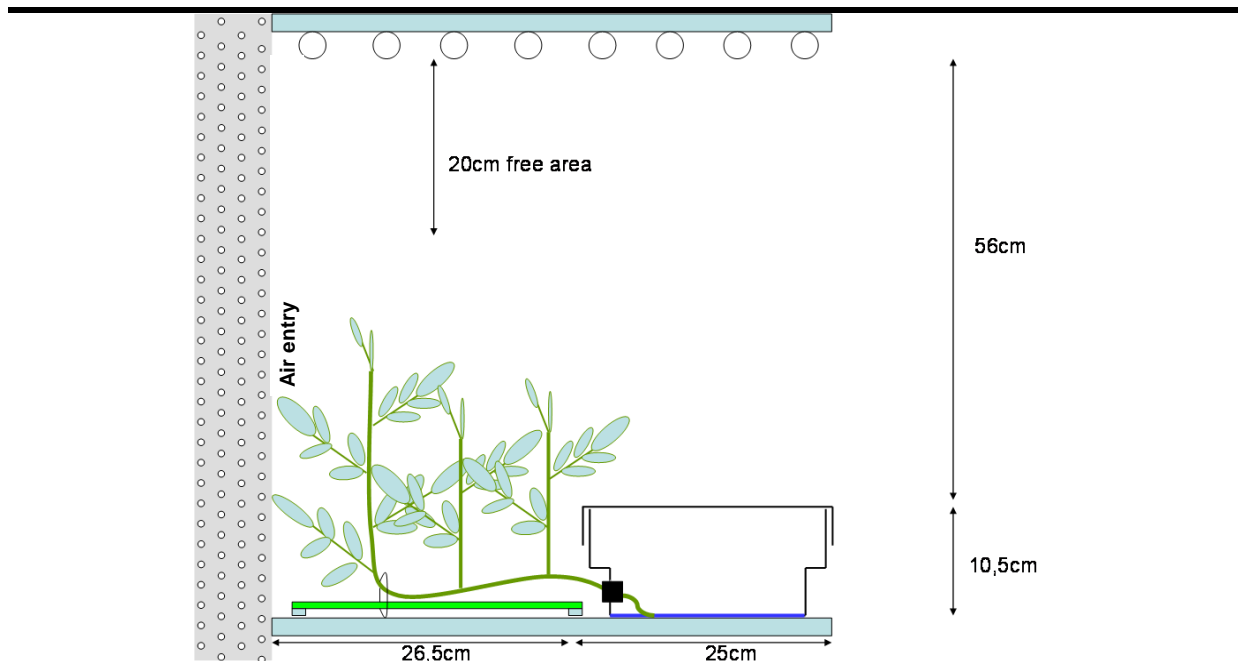

Fig. 38 Front view of a trough

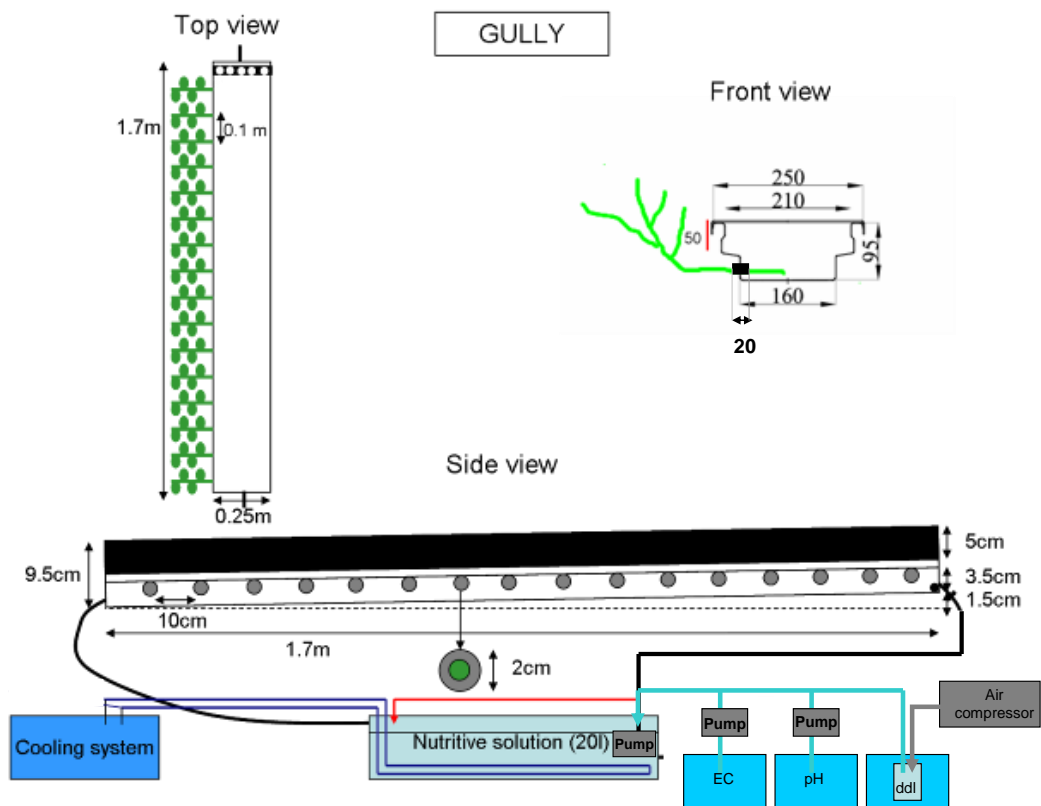

Fig. 39 Schematic of the hydroponic system

TN 98.4.11	Preliminary trade-off for test plan and procedures
UGent	
This document is confidential property of the MELiSSA partners and shall not be used, duplicated, modified or transmitted without their authorization	
Memorandum of Understanding 19071/05/NL/CP	

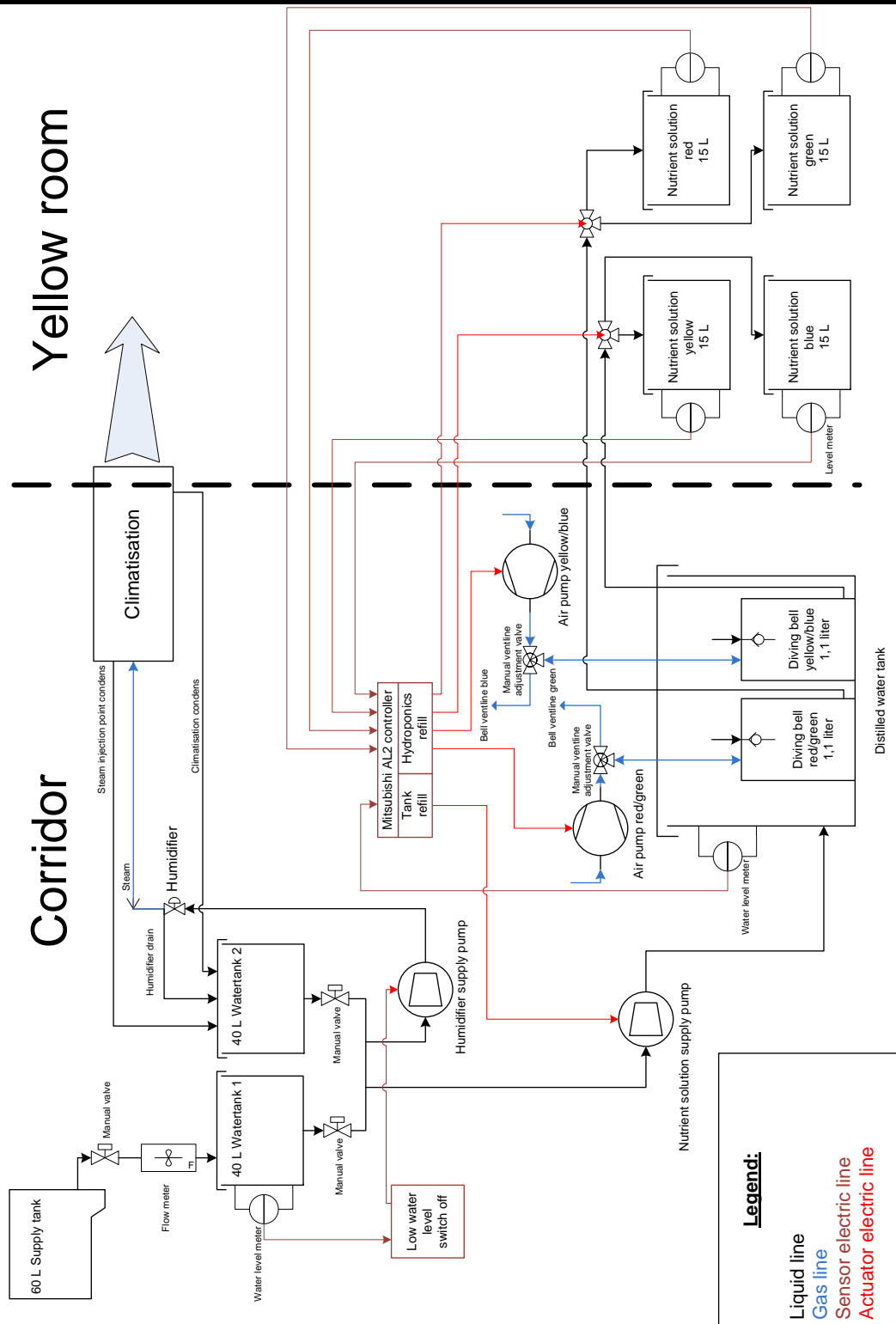

Fig. 40 Schematic of the water handling system

TN 98.4.11	Preliminary trade-off for test plan and procedures
UGent	
<p>This document is confidential property of the MELiSSA partners and shall not be used, duplicated, modified or transmitted without their authorization</p> <p>Memorandum of Understanding 19071/05/NL/CP</p>	

4.2.2 Hydroponic system material

Polyurethane coated stainless steel gullies produced by JBH (two of 1.7 m and two of 1.65 m long due to space constraints, 16 cm wide and 9.5 cm high).

Black polyethylene plastic covers delivered with the gullies.

Tanks made from food-grade black HDPE, submerged NJ1700 (l/h) pumps.

Cooling system TECO TR5 with 160W cooling capacity, MJ1000 circulation pump, one cooler is shared by two nutrient solution tanks.

Oxygen solubility decreases with temperature; the risk of anaerobic conditions is however estimated as low (high mixing rate by circulation pump, fast flow in the gully and thin nutrient solution layer – below 5mm), so no airpumps are installed.

Black rigid nylon tubing (8mm internal diameter, Norgren PA12) was used for the nutrient solution circuit.

PVC food grade tubing and valves for the bypass in the nutrient solution tanks (Georg Fisher PVC-U).

Silicone tubes for IRGA measurement setup.

Flexible transparent Polyethylene tubes for dosing pump connections (Hanna Instruments).

4.2.3 Pumps

Pump NJ1700

Pump out put: 1000-1700 L/h (nominal value without attached tubing)

Power consumption: 32 W

One bypass was placed at the pressure side of the pump to regulate the flow of nutrient solution and to provide mixing of the nutrient solution in the tank. A continuous flow is provided within the target range of 1-2 l/min (constant flow rate), independent of the pump delivery head of 0.4m (lower shelves) or 1.1m (upper shelves).

4.2.4 Substrate choice

No substrate is used; roots are grown in a thin nutrient solution layer (NFT).

4.2.5 Nutrient solution composition

The nutrient solution recipe as made available by the UGent consultant HZPC, and used at the UCL lab (Tab. 9) was slightly modified to assure the plants would fit in the limited rack space, As nitrogen determined shoot height, the nitrate amount was halved, theoretically corresponding to plants of 30-40cm height (with reference to greenhouse grown plants at HZPC).

The start up nutrient solution is replaced by a solution containing no nitrogen (Tab. 10) to induce efficient tuberisation by nitrogen starvation. The startup nutrient growth solution is thus entirely removed after three weeks and replaced by a tuberisation nutrient solution.

Nutrient solution samples are taken at the beginning of each new solution change and at the end of the 4 week interval. The volume of the nutrient solution is 15 litres per tank.

TN 98.4.11	Preliminary trade-off for test plan and procedures
UGent	
<p style="text-align: center;">This document is confidential property of the MELiSSA partners and shall not be used, duplicated, modified or transmitted without their authorization Memorandum of Understanding 19071/05/NL/CP</p>	

pH is kept at 5.5 with H₃PO₄

EC is kept at 2000 μS/cm with K₂SO₄ (startup) or KH₂PO₄ and K₂SO₄ (tuberisation)

Every 3 weeks one spoon of TENSO cocktail of oligo-elements is added.

Tab. 9 Growing phase nutrient solution composition

HZPC growing phase nutrient solution: plants of 30-40cm						
%		1L	4L	10L	15L	
5	ml	8.75	35	87.5	157.5	K ₂ SO ₄
10	ml	1.5	6	15	27	KH ₂ PO ₄
5	ml	5	20	50	90	Mg SO ₄
5.9	ml	6.25	25	62.5	112.5	Ca(NO ₃) ₂
6	ml	0.3125	1.25	3.125	5.625	iron-chelate
	g	0.05	0.2	0.5	0.9	TENSO cocktail (oligo-elements)

Tab. 10 Tuberisation phase nutrient solution composition

HZPC tuberisation phase nutrient solution: plants of 30-40cm						
		1L	4L	10L	15L	
%	ml	2.75	11	27.5	41.25	K ₂ SO ₄
5	ml	6.75	27	67.5	101.25	KH ₂ PO ₄
10	ml	3.75	15	37.5	56.25	Mg SO ₄
5	ml	0.3125	1.25	3.125	4.6875	iron-chelate
6	g	0.05	0.2	0.5	0.75	TENSO cocktail (oligo-elements)

4.2.6 Hydroponic system sensors

All sensor outputs (see Tab. 11) are logged to a DL2e data logger (delta-T devices, www.deltat.co.uk).

Tab. 11 Sensors choice for online measurement of required environmental parameters

In solution:	
Parameter	Sensor
Temperature	NTC 10K sensor (1 in each nutrient feeding tank)
O ₂ offline – manual measurement*	HI-914604 dissolved oxygen meter with HI 76407/4F electrode (Hanna Instruments) – measurement at pump water input
EC	HI700-221-2 Controller + HI7639 sensor and Pt100 T-sensor (Hanna Instruments)
pH	pH 500-1212 Controller + HI6101405 sensor and Pt-100 T-sensor (Hanna Instruments)

* Manual measurement and data transfer

TN 98.4.11	Preliminary trade-off for test plan and procedures
UGent	
This document is confidential property of the MELISSA partners and shall not be used, duplicated, modified or transmitted without their authorization	
Memorandum of Understanding 19071/05/NL/CP	

The pH and electrical conductivity (EC) are controlled automatically. The nutrient solution from each gully is measured once per minute.

EC: 1.8 mS/cm (expected value, based on information from HZPC)

pH: 5.5 (expected value, based on information from HZPC)

The automatic ON/OFF control based adjustment of pH and EC to the above defined setpoints was tested:

pH: See. Fig. 41 after manual addition (13:40) of a small quantity of 0.01M KOH to the nutrient solution tank (to reach a pH just above the setpoint), the controller automatically adds acid to balance the deviation from the setpoint. The figure shows how the nutrient solution pH reacts to the controller intervention.

EC: Fig. 42 shows the respective controller answer to a manual addition of 1l water to the nutrient tank at the EC setpoint. This emulates the automatic nutrient solution tank level control functionality during the plant growth test.

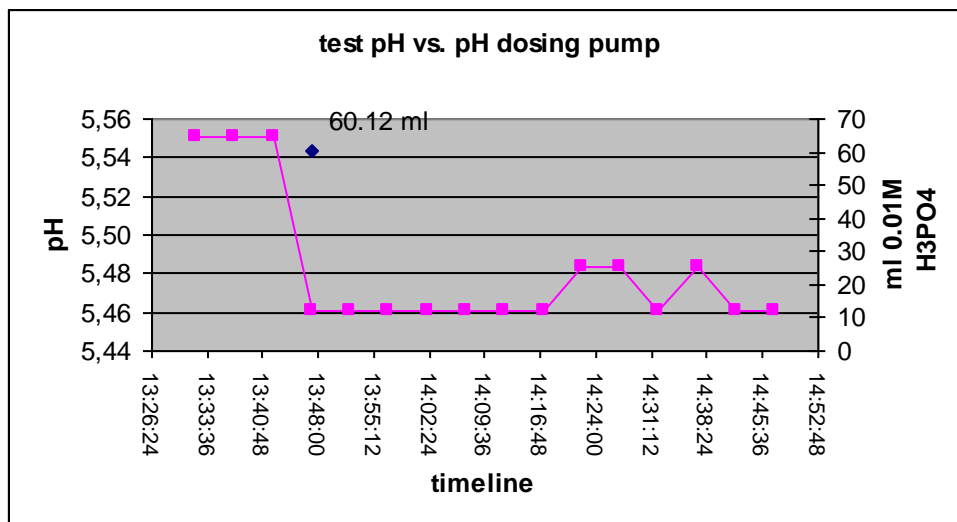

Fig. 41 Response of the nutrient solution pH to the automated acid addition

TN 98.4.11	Preliminary trade-off for test plan and procedures
UGent	
This document is confidential property of the MELiSSA partners and shall not be used, duplicated, modified or transmitted without their authorization	
Memorandum of Understanding 19071/05/NL/CP	

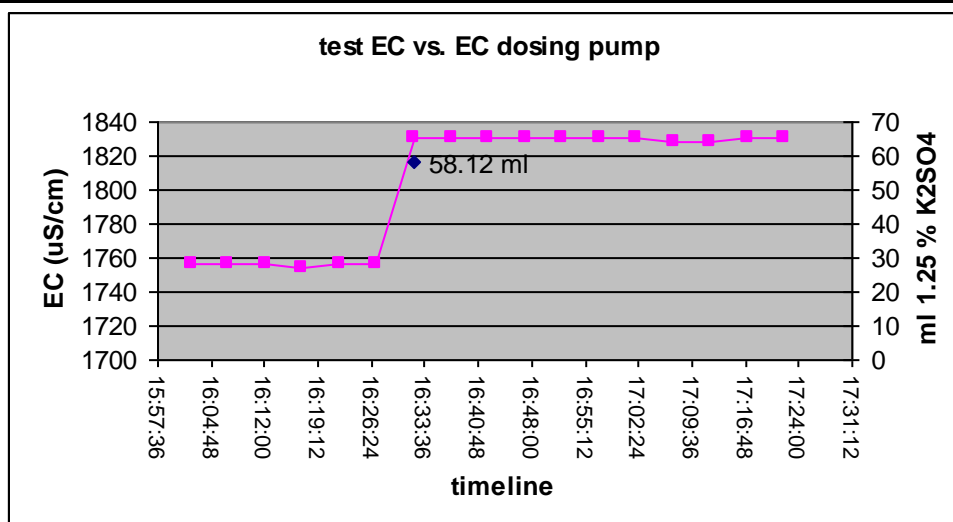

Fig. 42 Response of the nutrient solution EC to the automated base addition

4.2.7 Gully cleaning

The gullies are cleaned before start-up with detergent and rinsed with deionised water. The system is then run for 24 hours with deionised water.

Between plant growth trials, the gullies are cleaned with hot citric acid (when precipitations are visible), rinsed with deionised water, disinfected with bleach (NaOCl) and rinsed again with deionised water. The system is then run again for 24 hours with deionised water.

4.3 Experimental protocol

4.3.1 Cultivar selected

An overview of the selected cultivars' characteristics is given in Tab. 12.

Tab. 12 Characteristics of the potatoes cultivars selected for the FC phase 1

Cultivar	Yield FW (hydroponics)	DW in field	tuber size	Height	Maturity
Annabelle	High	Low 18,4%	Small	Medium-High	Very early
Bintje	Low	Medium to high	Medium to large	Medium	Early to intermediate
Desiree	Middle	21,40%	Large	Medium	Intermediate to late
Innovator	High	High 21,30%	Large	Medium to low	Early to intermediate

TN 98.4.11

UGent

Preliminary trade-off for test plan and procedures

This document is confidential property of the MELiSSA partners and shall not be used, duplicated, modified or transmitted without their authorization

Memorandum of Understanding 19071/05/NL/CP

4.3.2 *Acclimated in vitro-plants treatment*

For the start-up of the experiment in-vitro plantlets are used as they are disease free and at a homogeneous development state. These plants are produced by the consultant HZPC (Nederland). Acclimatisation takes place at HZPC for two weeks in an open hydroponic gully system.

Acclimated plants are too small to fit into the JBH gullies so they are first grown in smaller gullies (1.5 m x 15 cm x 4 cm) for the stem elongation phase (20°C, 80 $\mu\text{mol}/\text{m}^2\text{s}$ PAR).

All cultivars are grown with the HZPC growth nutrient solution from two common tanks.



Fig. 43 Potato vitro-plants after acclimatisation

4.3.3 *Culture conditions*

Potatoes are grown in four PU-coated stainless steel gullies (JBH) in a thin nutrient solution layer using a recirculating nutrient technique. Two types of gullies are available; two of 1.66 x 0.16 m which can both hold 15 plants and two of 1.7 x 0.16 m which contain 16 plants.

Each selected cultivar is grown in a separate gully (with its own nutrient solution).

In parallel, two extra gullies of the JBH type mentioned above are set-up in another controlled environment room (propagation room: room as used for the elongation phase) at a light intensity corresponding to the other 4 gullies. In this comparative experiment the 4 cultivars are setup in a mixed way in both gullies.

TN 98.4.11	Preliminary trade-off for test plan and procedures
UGent	
This document is confidential property of the MELiSSA partners and shall not be used, duplicated, modified or transmitted without their authorization	
Memorandum of Understanding 19071/05/NL/CP	

Tab. 13 Cultivars selected and quantity of plants

Cultivars	Number of plants	Gully position
Annabelle	15	Gully 2
Bintje	16	Gully 1
Desiree	16	Gully 3
Innovator	15	Gully 4

4.3.4 Plant growth period

In the first bench pre-test (carried out in propagation room), potatoes were grown with a 20 hour day and 4 hours dim light photoperiod (due to chamber control restrictions), and the switch from growing phase to tuberisation occurred after 5 weeks. The experiment lasted 4 months to final harvest. The growing period for further trials is also estimated to be four months.

4.3.5 Nutrient Solution Sampling

pH and EC are automatically measured. Sampling of hydroponics solution is performed at the beginning and end of nutrient solution change.

4.3.6 Plant development

Plant morphogenic development is measured weekly for the height, number of stolons, number of tubers, date of stolon appearance, date of tuber appearance, date of flowering and size of tubers.

4.3.7 Gas exchange measurements

An ADC-2250 open-loop gas exchange system will be used to measure single plant or single leaf CO₂ assimilation and transpiration. Such an infrared gas analysis system (IRGA) uses a pump to circulate air over the enclosed leaf surface in the cuvette, and determines the changes in concentration of CO₂ and H₂O as a function of time.

4.3.8 Imaging of leaf area and leaf temperature

The installed gantry robot is carried by a frame that is mounted vertically in the middle of the room. User access to the plants is through the same corridor. For user safety it is not possible to reach into the working area of the robot while an experiment is running. The robot can move in the x, y and z direction and furthermore the arm carrying the camera's can rotate (used components are toothed belt linear axis: <http://www.indunorm.eu>). All these movements are very precise (repeatability 0.1 mm) due to the use of closed-loop stepping motors (www.orientalmotor.de) and planetary gears (<http://www.alphagetriebe.de>). An application written with national instruments Labview (www.ni.com) controls both robot and image acquisition.

The vision components are a thermal infrared camera ThermoVision® A10 (pixel resolution 160x120; <http://www.flir.com>) and a BCi₅ CMOS colour camera (<http://www.vector-international.be>) capturing high-resolution colour images (1280x1024 pixels).

TN 98.4.11	Preliminary trade-off for test plan and procedures
UGent	
This document is confidential property of the MELiSSA partners and shall not be used, duplicated, modified or transmitted without their authorization	
Memorandum of Understanding 19071/05/NL/CP	

The firewire (IEEE1394) output of the A10 and the USB2 output of the BCI₅ camera are captured by a Labview application upon positioning of each of the cameras above the target plant. The software provides a module to compensate for the difference in alignment and field of view of the camera's, to obtain a perfect match between the different images sequences when analyzing the data.

4.3.9 Biomass data

Plant growth parameters to be measured at the end of the harvest are the fresh weight and the dry weight of roots, dry weight of stems and leaves, fresh weigh and size of tubers.

4.3.10 Yield estimation

Nutritional analysis of harvested potatoes will be carried out by IPL.

Tab. 14 Potato tuber nutrient analysis

Analyte		Analysis method (AOAC number if not otherwise stated)	mass of sample needed (DW)	(FW)
Moisture/ Dry matter		984.25 / 920.151A	2 g	10 g
	Ash	923.03	Same sample	
	Na, K	969.23 C	Same sample	
	Ca, Mg, Fe,Zn, Cu, Mn	985.35	Same sample	
	Cl	971.27	2 g	10 g
Proteins				
	Kjeldahl N	984.13	0,5 g	3 g
Lipids				
	Total (fast & cheap usual method)	ISO1443	4 g	20 g
Fibers				
	TDF	985.29	2 g	8 g
Glucids				
	total, by difference			0 g
Others				
	Vitamin C	EN14130 or AOAC 984.26 ¹	2 g	10 g
	P	IDF33A		
	Alkaloids	997.13	6 g	30 g

4.3.11 Timing of the measurements

For the harvest, fresh and dry weight of foliage, roots, stem and tuber fresh weight will be measured. After individual plant yield measurement, harvest will be divided in 2 classes as indicated in the table above (optimal light versus suboptimal light).

TN 98.4.11	Preliminary trade-off for test plan and procedures
UGent	
This document is confidential property of the MELiSSA partners and shall not be used, duplicated, modified or transmitted without their authorization Memorandum of Understanding 19071/05/NL/CP	

Tab. 15 Parameters and frequency of logging

		Frequency logging	Online/ Manual
Fixed	airflow		
	Solution flow	Weakly check	Manual
Daily measurements	Light quantity	5 min	Online
	Air temperature	30sec and 5 min	Online
	Humidity	30sec and 5 min	Online
	CO2 in air	5 min	Online
	O2 in air	5 min	Online
	Ethylene	1 min	Online
	Oxygen in solution	weekly	Manual
	pH	5 min	Online
	EC	5 min	Online
	Solution temperature	5 min	Online
	Weight gully 4	1 h	Online
	EC stock solution used	5 min	Online
	Water stock used	5 min	Online
	Acid/Base stock used	5 min	Online
	Video imaging	1 h	Online
	Thermal imaging	1 h	Online
Weekly measurements	projected leaf area: images from video cam on robot		Online
	leaf temperature: images from thermal cam on robot		Online
	tuber area measurement – manual / image analysis of captured images		Manual
	CO2 assimilation ADC2250 IRGA system with small leaf cuvette or whole plant cuvette		Online / 1day period
	Leaf transpiration ADC2250 IRGA system with small leaf cuvette or whole plant cuvette		Online / 1day period
	Ethylene emanation measurement Sensorsense system small leaf cuvette or whole plant cuvette		Online / 1day period
	O2 level in leaf cuvette or whole plant cuvette		Online / 1day period
	Plant height		Manual
	Number of stolons		Manual
	Number of tubers		Manual
	Date of stolon appearance		Manual
	Date of tuber appearance		Manual
	Date of flowering		Manual
Week 3, 8 and harvest	Complete nutrient solution composition control		Manual
Harvest	Foliage fresh weight		Manual
	Stem fresh weight		Manual
	Root fresh weight		Manual
	Tuber fresh weight		Manual
	Foliage dry weight		Manual
	Stem dry weight		Manual
	Root dry weight		Manual
	Nutritional analysis by IPL, average per category		Manual
	plant 1-4 suboptimal light		Manual
	plant 5-12 optimal light		Manual
	plant 13-16 suboptimal light		Manual

TN 98.4.11

UGent

Preliminary trade-off for test plan and procedures

This document is confidential property of the MELiSSA partners and shall not be used, duplicated, modified or transmitted without their authorization

Memorandum of Understanding 19071/05/NL/CP

4.3.12 Preliminary testing

A pre-test experiment with 2 gullies was setup to determine if the hydroponic system would be performing well. Six cultivars (Berber, Bintje, Carlita, Desiree, Felsina, Vitelotte) were grown under controlled conditions (20 h light plus 4h dim light, 70% RH, 19 to 24°C, pH 5.5 and EC 1500 μ S). All cultivars produced tubers (Fig. 44) but excessive stem elongation and root production was observed. The growth of a large root mass led to an elevated solution level in the gullies and subsequent overflowing. Therefore, for the FC phase 1 bench-test, the general nutrient solution initially used was replaced by the 2 nutrient solutions prepared according to recipes supplied by HZPC. This mitigated excessive development of roots and shoots. Use of the HZPC tuberisation solution in one of the gullies during the preliminary test proved to control shoot growth to the desired size.



Fig. 44 Tubers produced from the preliminary experiment

TN 98.4.11	Preliminary trade-off for test plan and procedures
UGent	
<p>This document is confidential property of the MELiSSA partners and shall not be used, duplicated, modified or transmitted without their authorization</p> <p>Memorandum of Understanding 19071/05/NL/CP</p>	

Potato (UCL)

The UCL-GRPV has growth chambers with controlled temperature and photoperiod. The growth chamber that is used for the MELiSSA project contains a height-adjustable light ceiling with adjustable photoperiod. The growth chamber was adapted for the hydroponic culture of potato.

4.4 Growth chamber specifications

Four separate liquid systems (one per cultivar) are used (Fig. 45).

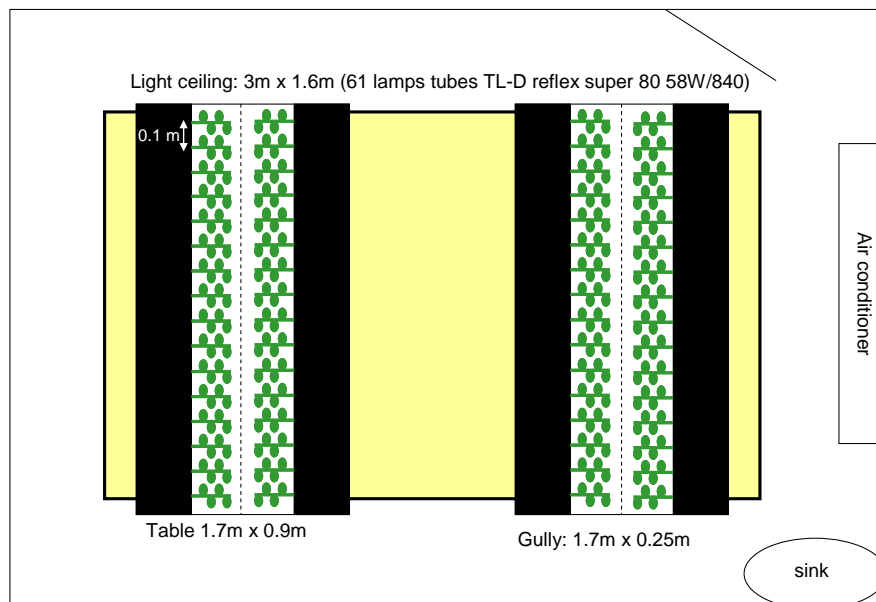

Fig. 45 Schematic representation of the growth room in Louvain-la-Neuve

Two tables of 1.7m x 0.9 m are located under the light ceiling, subsequently termed Table 2 (on the left in Fig. 45), and Table 1 (on the right). On each table, two gullies (1.7 m x 0.25 m) are used. The gullies are positioned on the borders of the tables so that the plants can grow in the centre (Fig. 45). A fence (mesh size 2cm x 2cm) of 40 cm height separates the two sides. There are 16 plants per gully (10 cm space between plants). The plants are accessible from all sides of the tables, which are located centrally in the chamber of 4.8x2.5m.

TN 98.4.11	Preliminary trade-off for test plan and procedures
UGent	
This document is confidential property of the MELiSSA partners and shall not be used, duplicated, modified or transmitted without their authorization	
Memorandum of Understanding 19071/05/NL/CP	

4.4.1 Lighting

The light ceiling contains 61 fluorescent lamp tubes (TL-D reflex super 80 58W/840 Philips, Fig. 46) and can be moved to adjust the distance between the plants and the lamps. Each second lamp can be turned on/off independently to adjust light homogeneity (Fig. 47). As the harvest will be divided in two parts concerning the influence of light level on nutritional composition, the lamps at the edges of the table were turned off. The pattern shown assures the intensity is equally distributed over the gullies of the 4 cultivars.

The distance between the table and the light is maintained at 1m during the whole experiment. Light intensity was measured at table level, at 20cm above the table and at 40cm above table level, the latter anticipated as being the maximum plant height to be attained.

- Light intensity: $\pm 200-300 \mu\text{mol}/\text{m}^2\text{s}$ PPFD (Fig. 48, trace 0cm, corresponding to table level); PAR quantum sensor (single channel light measuring system SKP 215, Skye instruments LTD.; range 0-20000 $\mu\text{mol}/\text{m}^2\text{s}$; accuracy $\pm 3\%$; wavelength 400-700 nm).
- Photoperiod: 16h light/8h dark; ON/OFF control system.

Preferred selection

Type	Packaging Configuration	Net weight per piece (g)	Dim. no.	Cap/ Base	Colour Designation	Colour Temperature (K)	Colour Rendering Index (R _a)	Chromaticity Coordinate X	Chromaticity Coordinate Y
MASTER TL-D Reflex Super 80 58W/840 SLV	25	186.0	3	G13	Cool White	4000	85	376	374
Type	Lamp Voltage (V)	Lamp Wattage EM (W)	Lamp Current EM (A)	Luminous Flux Lamp EM (lm)	Luminous Efficacy Lamp EM (lm/W)	Luminance Average EM (cd/cm ²)	Energy Efficiency Label	ILCOS	EOC
MASTER TL-D Reflex Super 80 58W/840 SLV	111	58.5	0.67	5200	89	2.62	A	FDR-58/40/1B-E-G13	8711500 559623 40

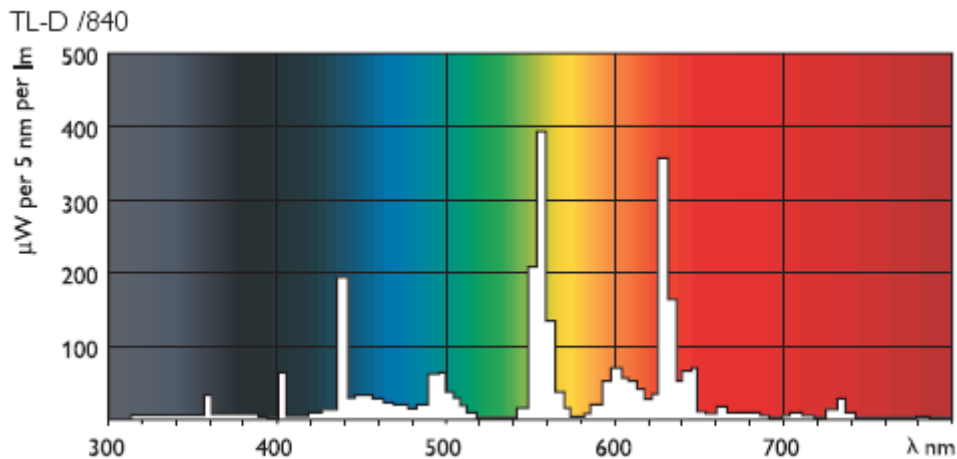
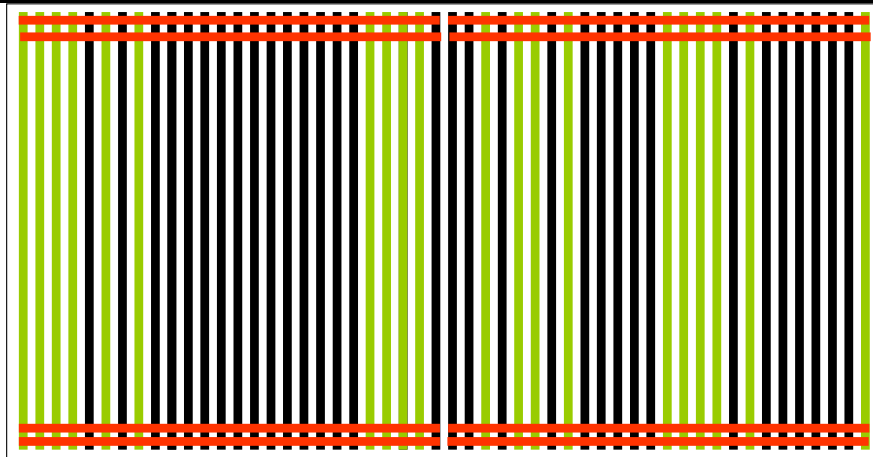

Fig. 46 Philips TL-D reflex super 80 58W/840 specification and spectrum

TN 98.4.11	Preliminary trade-off for test plan and procedures
UGent	
<p>This document is confidential property of the MELiSSA partners and shall not be used, duplicated, modified or transmitted without their authorization</p> <p>Memorandum of Understanding 19071/05/NL/CP</p>	



Tubes positions on the light ceiling

Lamps turned off because some are not working and to increase the light intensity difference along the gullies

Lamps turned off to have the more homogene light intensity possible

Fig. 47 Map of the light ceiling

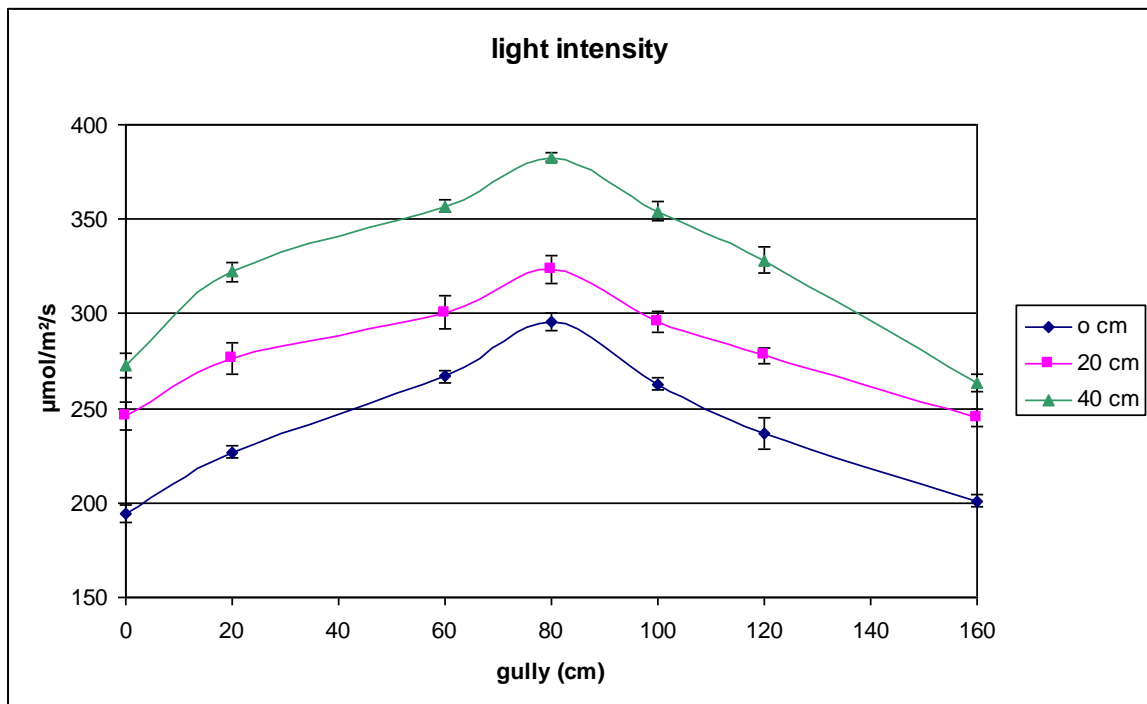

Fig. 48 Light intensity along the gullies with standard deviation between gullies.

In Fig. 48 the “40cm” trace corresponds to plants of maximum height, 40cm above table level.

TN 98.4.11	Preliminary trade-off for test plan and procedures
UGent	
This document is confidential property of the MELiSSA partners and shall not be used, duplicated, modified or transmitted without their authorization	
Memorandum of Understanding 19071/05/NL/CP	

4.4.2 Environment control

The temperature in the room is adjusted by an air conditioner (cooling system slit-system HITACHI type RPC-4AQ2/RAS-4AQQ2). The evaporator unit is in the room. The condenser unit is located outside on the roof. The cooling capacity is 10.6 kW. The dimensions of the fan/evaporator unit are 1300x225x625 mm (Fig. 52).

The setpoints for temperature is 20°C; the range of measured values is as follows:

- Temperature: 20°C - 25°C
- Relative humidity: 60 - 90%

Temperature and relative humidity is measured by data loggers (Tinytag view 2). One data logger is used on each table (called *Melissa 1* and *Melissa 2*). Another data logger is positioned between both tables (not directly illuminated by the lamps, called *chamber*) (Fig. 49 to Fig. 51). The data loggers' main technical specifications are as follows:

- Measurement interval: 10 min
- Operating range: -25°C to +50°C; 0-100%RH
- Accuracy: 0.4°C; 3% RH at 25°C

The complete specification sheet is available on the UGent fileserver or through: <http://87.117.252.3/images/downloads/451.pdf>

An overheating sensor (thermostat) is installed in the room (Fig. 52). This security thermostat switches off the lights when the temperature increases over 30°C.

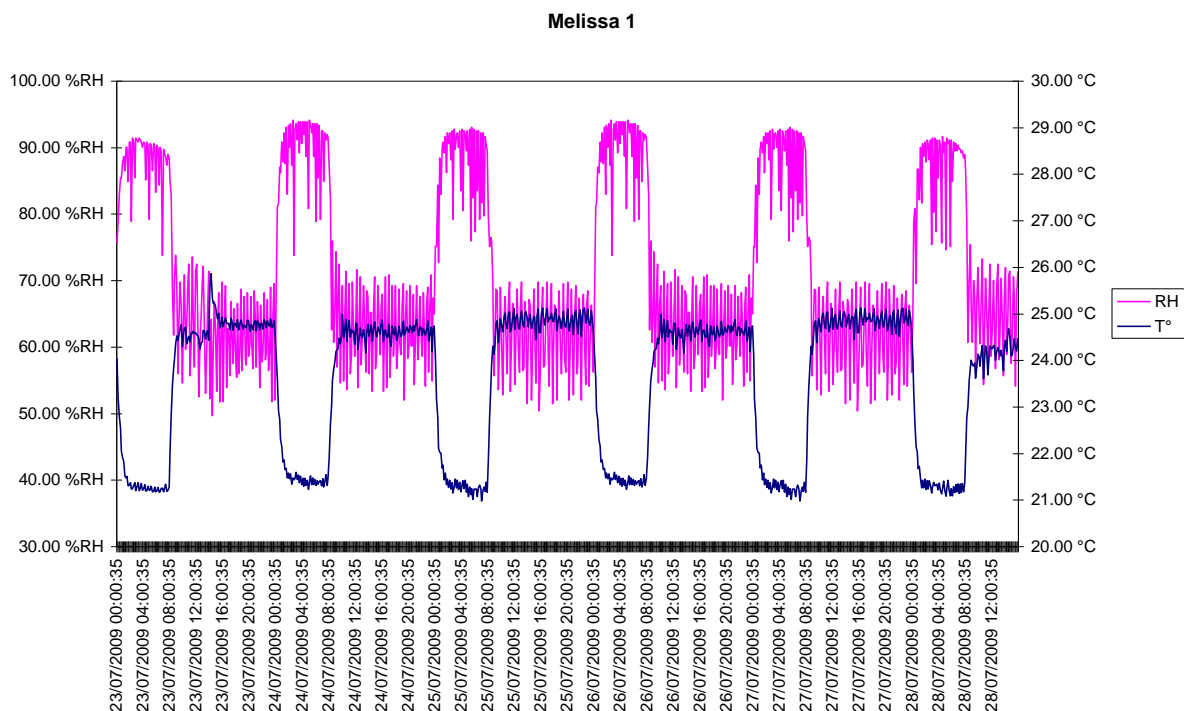

Fig. 49 RH and temperature on table1 next to the door and the fan unit

TN 98.4.11	Preliminary trade-off for test plan and procedures
UGent	
This document is confidential property of the MELISSA partners and shall not be used, duplicated, modified or transmitted without their authorization	
Memorandum of Understanding 19071/05/NL/CP	

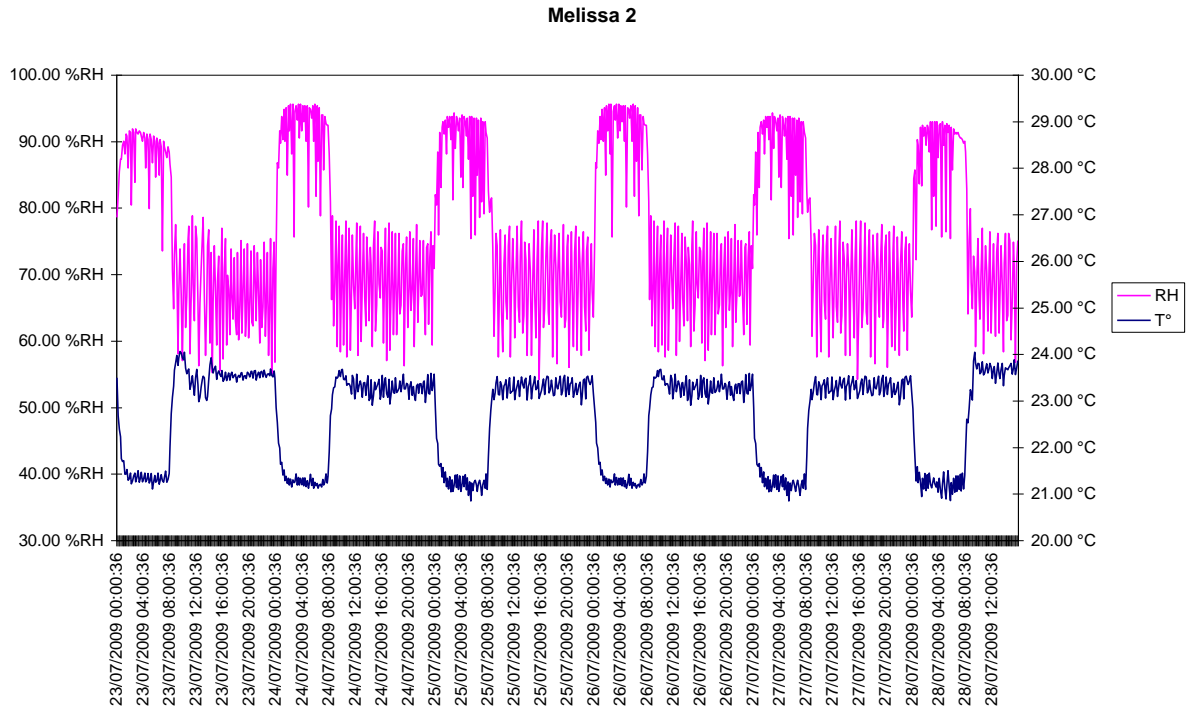

Fig. 50 RH and temperature on table2

chamber

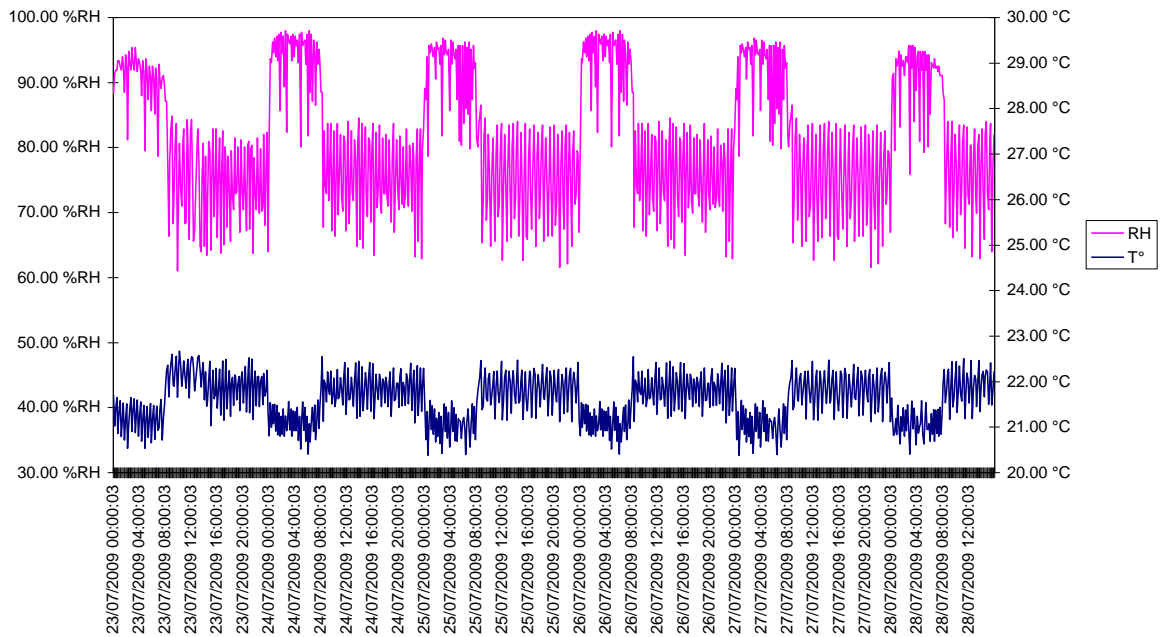

Fig. 51 RH and temperature in the middle of the room (no direct contact with the lamps)

TN 98.4.11	Preliminary trade-off for test plan and procedures
UGent	
<p>This document is confidential property of the MELiSSA partners and shall not be used, duplicated, modified or transmitted without their authorization</p> <p>Memorandum of Understanding 19071/05/NL/CP</p>	

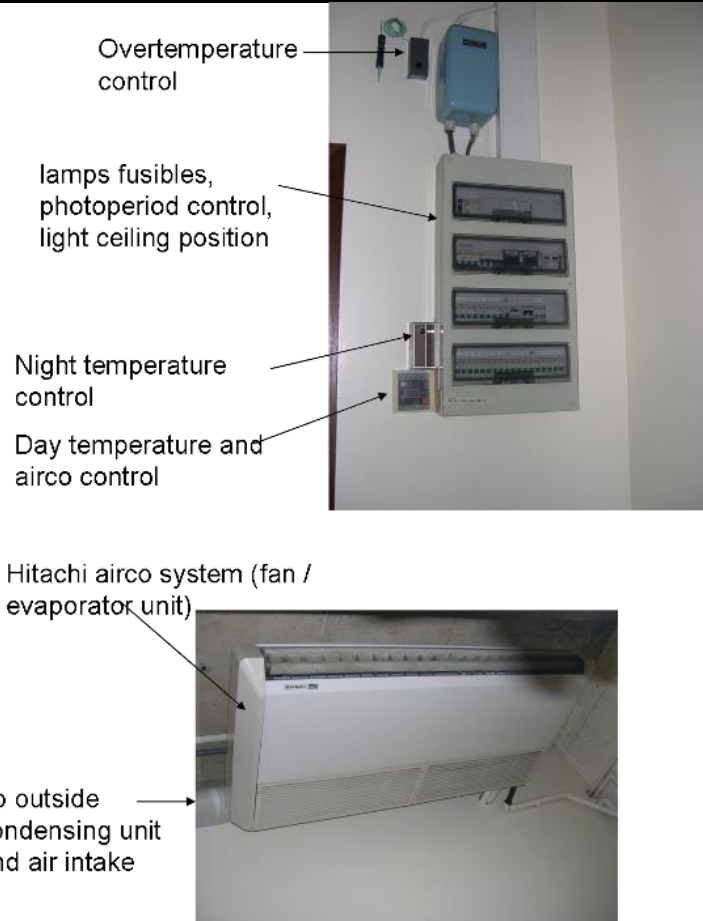

Fig. 52 Temperature control system in the growth room

TN 98.4.11	Preliminary trade-off for test plan and procedures
UGent	
<p>This document is confidential property of the MELiSSA partners and shall not be used, duplicated, modified or transmitted without their authorization</p> <p>Memorandum of Understanding 19071/05/NL/CP</p>	

4.4.3 Hydroponic system

The hydroponic system is based on recirculating closed NFT. Four separate systems are used (one per trough, Fig. 53 and Fig. 54).

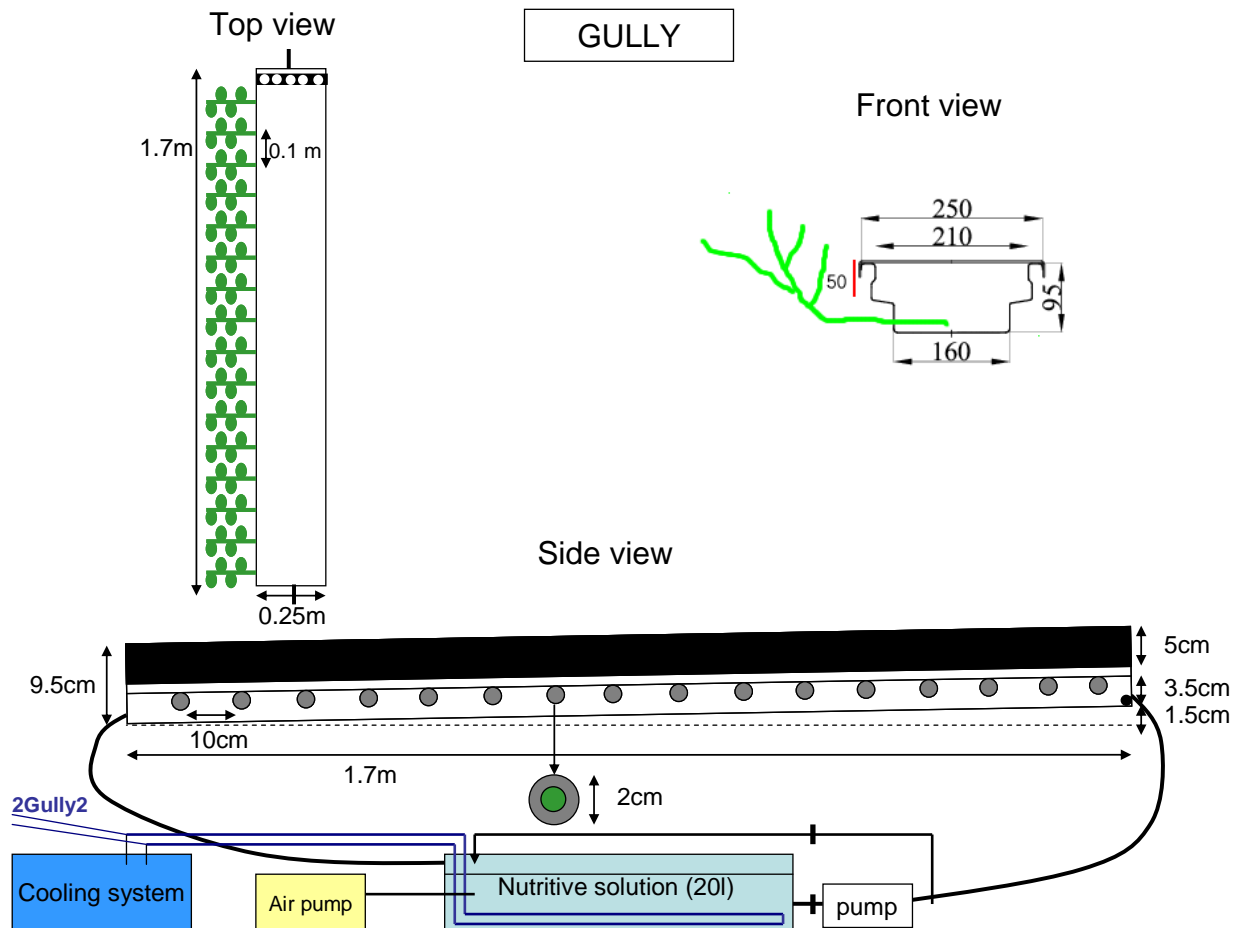

Fig. 53 Recirculating closed NFT hydroponic system for potatoes.

TN 98.4.11	Preliminary trade-off for test plan and procedures
UGent	
This document is confidential property of the MELiSSA partners and shall not be used, duplicated, modified or transmitted without their authorization	
Memorandum of Understanding 19071/05/NL/CP	

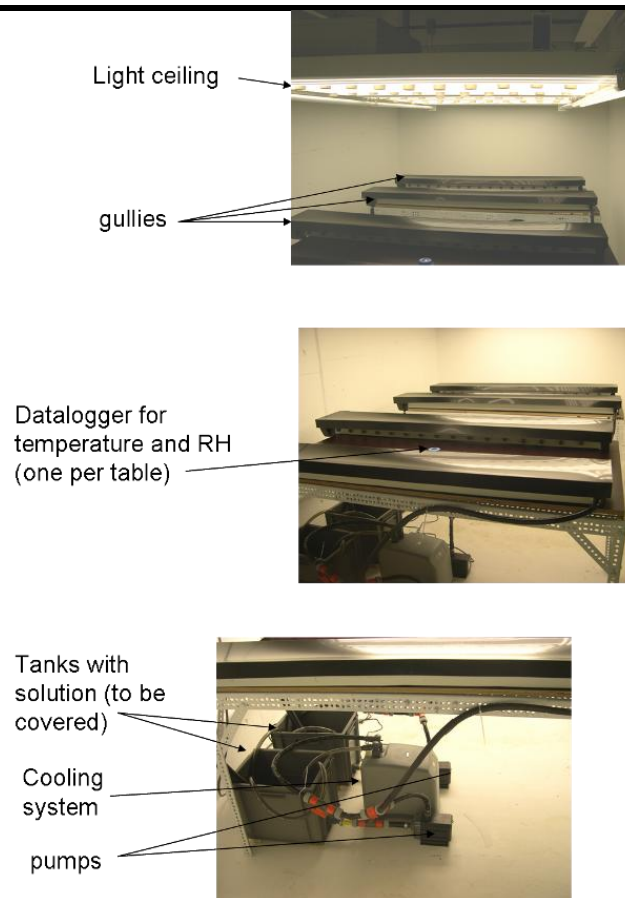

Fig. 54 Gullies and hydroponic systems

Each of the four systems consists of:

- One galvanized steel trough with PU coating (1.7 m x 0.25 m x 0.95 m, JBH Guttersystem 250/200-95, JB Hydroponics, Maasdijk, NL) with an inclination of 1.5 cm on 1.7 m length.
- One 30 L food grade PP tank (Allibert) containing 20 L of nutrient solution.
- One centrifugal (non-priming) pump (Eheim universal 1260 submersible) with 2400 L/h capacity, mounted outside of the nutrient solution tank to reduce the heat load.
- A connection before the pump to disconnect the pump if necessary.
- A 2 way divider connection allowing the recirculation of the nutrient solution to the tank after the pump.
- PVC Tubing with a 16/22 mm (internal/external) diameter.

The systems share:

- One cooling system (Teco cooler TR5 160W) per table (one cooler for two tanks).
- One air pump (Superfish Koi-flow 60) (60L/min) to oxygenate the nutrient solutions (one for the 4 gullies).

TN 98.4.11	Preliminary trade-off for test plan and procedures
UGent	
<p>This document is confidential property of the MELiSSA partners and shall not be used, duplicated, modified or transmitted without their authorization</p> <p>Memorandum of Understanding 19071/05/NL/CP</p>	

4.4.4 Nutrient solution

- Flow rate: 5 l/min per gully.
- Composition, EC, pH: The same recipes and protocols as UGent (Tab. 9 and Tab. 10).
- Temperature: 20°C.
- Each system contains 20 L of nutrient solution. The solution level is checked each week and adjusted when needed.
- After 5 weeks tuberisation solution with less N replaces the start up solution. After 10 weeks the nutrient solution is exchanged.
- EC and pH are controlled manually every day with a Symphony SP90M5 meter (see Tab. 16). The adjustments are done by adding demineralised water, concentrate solution, KOH or HNO₃.
- O₂ level is manually measured daily with a Symphony SP90M5 oxygen meter.
- Solution T is manually measured daily (Symphony SP90M5).
- Control of nutrient solution composition is determined at the beginning of the experiment, after 5 weeks (old and fresh), after 10 weeks (old old and fresh) and at the end of the experiment. Three replicates are taken per sampling.

K, Ca, Mg, Fe, Mn, Zn, Cu, Na, P, S, Mo, B, Cr, Pb, Al are measured with an ICP (inductively coupled plasma) system. NO₃⁻, NO₂⁻, NH₄⁺, PO₄³⁻, Cl⁻, SO₃⁻ levels are measured by HPLC in the UCL/SOLS laboratory.

Additionally, the concentration of NO₃⁻ (Merck Microquant® (MiQ)), SO₄²⁻ (Aquaquant® (AQ)), PO₄³⁻ (Aquamerck® (AM)) can be determined with test sticks during plant development (Tab. 17) and the amounts of K, Ca, Mg are measured by atomic absorption spectrophotometer (AAS4, Thermo scientific). The nutrient solution is injected in the machine after filtration (0.45 µm filter). The minimum detection levels are 0.008 mg/l, 0.009 mg/l and 0.003 mg/l for K, Ca and Mg respectively.

4.4.5 Microorganisms monitoring

At the beginning of the experiment, after 5 weeks, after 10 weeks and at the end of the experiment, the total count for bacteria and fungi in the nutrient solution is determined. This is only scheduled for UCL. Other partners do not perform this analysis.

The quantity of microorganisms in the nutrient solution is determined by the total viable count (TVC). PCA (Plate Count Agar) will be used to monitor the number of bacteria. Plates are incubated for 3 days at 37°C. YGC (Yeast Extract Glucose Carbonate medium) will be used to monitor the number of yeast and mould. The plates are incubated for 5 days at 25°C.

Well isolated colonies will be counted to obtain first indications of the global microbial population.

Tab. 16 Specifications of the Symphony SP90M5 meter (pH, EC, O₂, temperature)

	Range	Accuracy	Resolution
pH	-2 to 20	0.002	0.001
Conductivity	3000 mS/cm	Not specified	Not specified
DO	0 to 9 mg/l	0.2 mg/l	Not specified
T	-5 to 105	Not specified	0.1

TN 98.4.11

UGent

Preliminary trade-off for test plan and procedures

This document is confidential property of the MELiSSA partners and shall not be used, duplicated, modified or transmitted without their authorization

Memorandum of Understanding 19071/05/NL/CP

Tab. 17 Test sticks specifications

element	method	range	accuracy
NO ₃ ⁻	colorimetric	5-90 mg/l	5 mg/l
SO ₄ ²⁻	colorimetric	25-300 mg/l	25 mg/l
PO ₄ ³⁻	colorimetric	1.3-13.4 mg/l	1.5 mg/l

4.5 Test plan

4.5.1 Setup and protocol for germination and propagation

In vitro plants are used as starting material: 16 plants per cultivar are put in the gullies (one gully per cultivar) using a nutrient solution with normal nitrate content. The space between the plants in the gullies is 10 cm. The 4 cultivars used are Annabelle, Bintje, Désirée and Innovator. In vitro plants are provided by HZPC (20 plants per box). The size of the in vitro plants before transfer to the gullies is about 10 cm. The plants are rinsed to remove the agar and placed immediately in the gullies.

After 5 weeks (formation of the first stolons), the solution is replaced by a low nitrate tuberisation solution. The plants are maintained in this nutrient solution until the end of the experiment (nutrient solution is renewed once at week 10). The plants are harvested after \pm 100 days of growth.

The plants are cultivated in 16h/8h (day/night) photoperiod at a light intensity of 200-300 $\mu\text{mol}/\text{m}^2\text{s}$. The temperature is maintained around 20-25°C and the relative humidity around 60-90%. The temperature of the nutrient solution is controlled and must be maintained at 20°C.

Cultivar layout in the growth chamber: see Fig 40. from left to right Innovator, Bintje, Annabelle, Desiree

4.5.2 Observation parameters for the plants

The growth of the plants is followed every week for each plant:

- Plant height
- Number of leaves
- Number of stolons
- Number of tubers
- Date of stolon formation
- Date of tuberisation
- Date of flowering
- Number of stolons and tubers
- Percentage of gully covered by the roots (using visual spectrum images and specific software; involvement of UCL-EPAV consultant specialised in this topic)

TN 98.4.11	Preliminary trade-off for test plan and procedures
UGent	
This document is confidential property of the MELISSA partners and shall not be used, duplicated, modified or transmitted without their authorization	
Memorandum of Understanding 19071/05/NL/CP	

The physiological parameters of the plants are followed every week for each plant on the youngest expanded leaf (young leaf photosynthetic active, Tab. 18):

- Net photosynthesis and instantaneous transpiration (portable Infra Red Gas analyzer LCA4 ADC Bioscientific Ltd):

The LCA4 instrument provides measurement of CO₂ and H₂O exchanges associated with a leaf specimen enclosed in an ADC'PLC' type of leaf chamber. Instantaneous CO₂ assimilation rate ($\mu\text{mol CO}_2 \cdot \text{m}^{-2} \cdot \text{s}^{-1}$) and instantaneous transpiration rate ($\text{mmol H}_2\text{O} \cdot \text{m}^{-2} \cdot \text{s}^{-1}$) are determined by monitoring depletion of CO₂ and H₂O.

- Stomatal conductance (porometer AP4 deltaT):

Stomatal aperture is the dominant factor in the diffusion conductance of leaf surfaces, which controls both the water loss from plant leaves and the uptake of CO₂ for photosynthesis. The AP4 measures diffusion conductance by comparing the precise rate of humidification within a small cuvette to readings obtained with a calibration plate.

- Kinetics of chlorophyll fluorescence (fluorescence monitoring system 2 Hansatech Instruments):

The leaf portion is acclimated to darkness for 30 min. Fluorescence is measured at 12 bit resolution and excited by six light emitting diodes providing a saturating beam of actinic red light (650 nm, 600 W/m², 3200 $\mu\text{mol} \cdot \text{m}^{-2} \cdot \text{s}^{-1}$). Maximum yield of photochemistry (F_v/F_m), absorbance per cross section (ABS/CS, antenna size), number of reaction center in cross section (RC/CS), rate of primary photochemistry per cross section (TR_0/CS_0), electron transport per cross section (ET_0/CS), as well as the dissipation energy per cross section (DI_0/CS) and the performance index (PI) were measured according to the JIP method of Strasser and Strasser (1995) which implies the measurement of a fast fluorescence transient with a 10 μs resolution in a time span of 40 μs to 1 s to allow the dynamic measurement of a photosynthetic sample at a given physiological state.

- Chlorophyll concentration SPAD (CCM-200 opti-sciences):

The cell (3 cm of diameter) of the machine is attached to the leaf. Chlorophyll has several distinct optical absorbance characteristics that the CCM-200 uses to measure relative chlorophyll concentration without destructive sampling.

- Leaf area meter (area meter AM 300 ADC Bioscientific Ltd):

The AM300 consists of a high resolution scanner and a scan board with integral data analysis and image storage. An adjustable contrast control makes the AM300 suitable for damaged, discoloured or diseased leaf applications.

Tab. 18 Specifications of instruments for physiological parameters

Measured value	Device	Measurement range	Accuracy
IRGA	LCA4 ADC	CO ₂ : 0-1600 H ₂ O: 74 ‰ (at 40°C)	CO ₂ : 0.2 vpm H ₂ O : 0.5% fsd
Porometer	AP4 delta T	5-12000 mmol/m ² s	± 10%
Chlorophyll fluorescence	FMS2	PAR: 0-20000 $\mu\text{mol}/\text{m}^2\text{s}$ T: -10°C - 90°C	
Chlorophyll content meter	CCM-200		± 1 CCI unit
Leaf area meter	ADC AM 300	Max width = 100 mm	± 2%

TN 98.4.11	Preliminary trade-off for test plan and procedures		
UGent			
This document is confidential property of the MELISSA partners and shall not be used, duplicated, modified or transmitted without their authorization			
Memorandum of Understanding 19071/05/NL/CP			

In addition to the above mentioned non-destructive measurements, destructive measurements are performed after the harvest for each plant:

- Fresh weight of the leaves, stems, roots, tubers (for each tuber and total per plant).
- Dry weight of the leaves, stems, roots.
- Total soluble sugar content and starch content in the leaves and the roots according to Yemm and Willis (1954):

1g of frozen samples (young leaf, old leaf, roots) is ground in liquid nitrogen to a fine powder and then extracted with 4 ml of 70% ethanol. Extracts are centrifuged for 15 min at 6600 g. The supernatant is used for the quantification of the total soluble sugar content. Starch in the pellet is hydrolyzed in 8 ml HCl 1 M at 95°C for 2 hours and filtered on Miracloth. The solution is neutralized with NaCl. For both fractions, 1 ml of Anthrone solution (250 ml H₂SO₄cc + 12.5 ml H₂O + 0.5 g Anthrone) is added to 200 µl of sample and boiled for 10 minutes. Then the OD is measured at 625 nm.

- carbon isotopic discrimination (¹³C versus ¹²C discrimination by photosynthesis depends on stomatal aperture) in order to evaluate the water-use efficiency (WUE, ratio of energy captured by photosynthesis per unit of water transpired, depends on efficient regulation of stomatal aperture) on young and old leaves :

1 g of tissue (DW) is ground to a fine powder. Carbon isotope composition ($\delta^{13}\text{C}$) is determined in duplicate for each sample with an isotope mass spectrometer (Isotope Services Inc, Los Alamos, NM, USA) and calculated with respect to PeeDeeBelemnite reference as $\delta^{13}\text{C} (\text{‰}) = [(R_{\text{sample}}/R_{\text{reference}}) - 1 \times 1000]$ where R is ¹³C/¹²C ratio. Carbon isotope discrimination (Δ) is calculated according to the formula of Hubick et al. (1986): $\Delta = [(\delta_a - \delta_p)/(1 + \delta_p)] * 1000$ where δ_p is the $\delta^{13}\text{C}$ of the leaf sample and δ_a is the $\delta^{13}\text{C}$ of the atmospheric CO₂ (- 8‰).

This measurement gives an integrated assessment of stomatal conductance over the development time of the samples tissue. Manual gas exchange measurements only provide time point measurements.

At harvest, for each cultivar the tubers are divided into two classes based on the light intensity received by the parent plants (low intensity/high intensity). Immediately after harvest, or after 1 week of hardening, tubers are sent to IPL for further analysis. To assess longer term storage ability tubers can be stored at 4 to 6°C in the dark in order to evaluate tuber dormancy. Tubers are kept at 6°C in the dark and the time to produce sprouts is logged.

TN 98.4.11	Preliminary trade-off for test plan and procedures
UGent	
This document is confidential property of the MELiSSA partners and shall not be used, duplicated, modified or transmitted without their authorization	
Memorandum of Understanding 19071/05/NL/CP	

REFERENCES:

Hubick KT, Farquhar GD, Shorter R (1986) Correlation between water-use efficiency and carbon isotope discrimination in diverse peanut (*Arachis*) germplasm. *Aust J Plant Physiol* 13: 803–816

Strasser BJ , Strasser RJ (1995). Measuring fast fluorescence transients to address environmental questions: the JIP-test. In: Mathis P, ed. *Photosynthesis: From Light to Biosphere*. vol. V. Kluwer Academic Press, Dordrecht . pp. 977–980.

Yemm EW, Willis J (1954) The estimation of carbohydrates in plant extracts by anthrone. *Biochem J* 57: 508–514

TN 98.4.11	Preliminary trade-off for test plan and procedures
UGent	
This document is confidential property of the MELiSSA partners and shall not be used, duplicated, modified or transmitted without their authorization Memorandum of Understanding 19071/05/NL/CP	

4.6 Summary

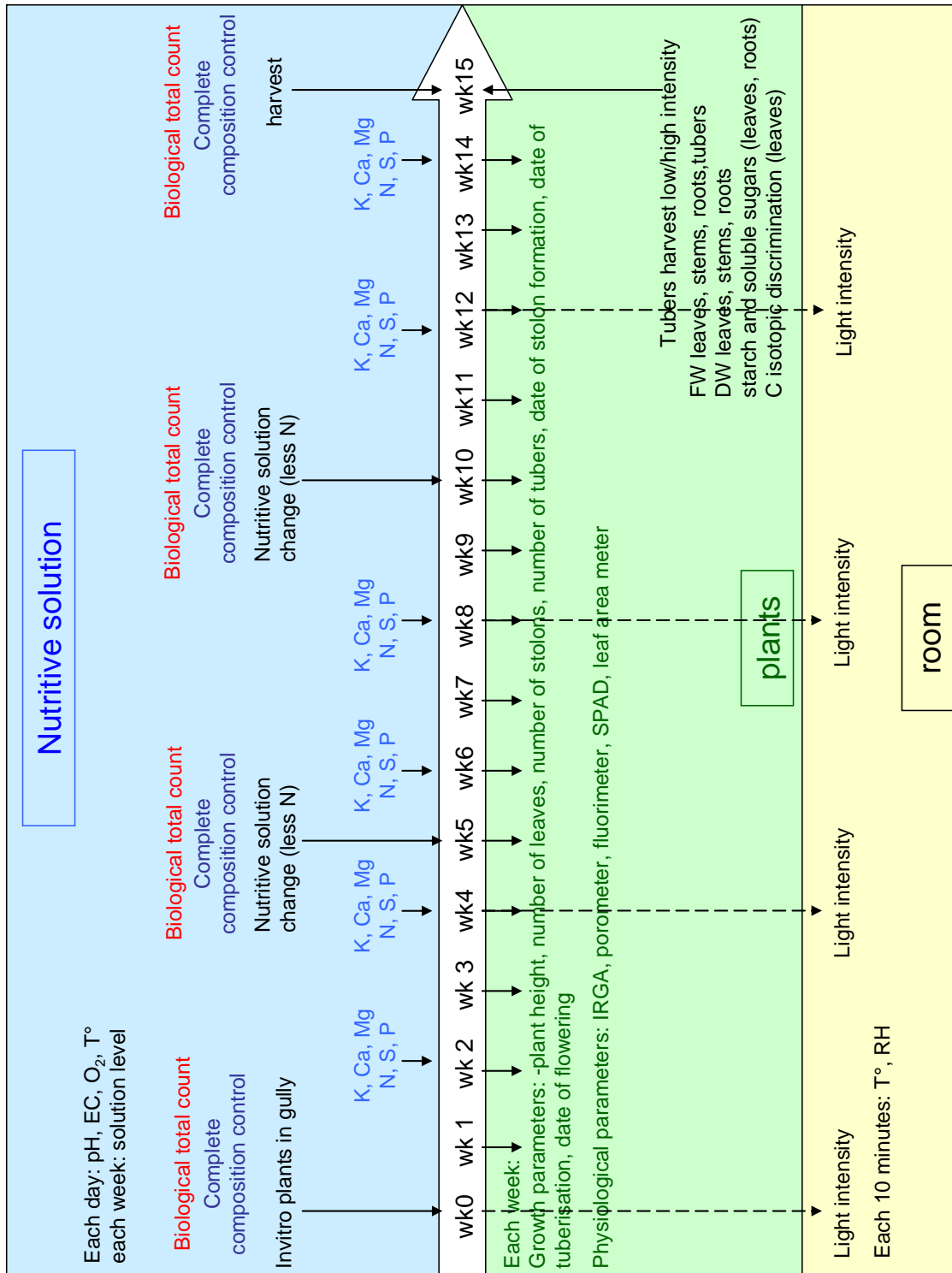

TN 98.4.11	Preliminary trade-off for test plan and procedures
UGent	
<p>This document is confidential property of the MELISSA partners and shall not be used, duplicated, modified or transmitted without their authorization</p> <p>Memorandum of Understanding 19071/05/NL/CP</p>	

5 Soybean

The bench tests on the soybean cultivars are performed at the University of Napoli. One walk in growth chamber has been adapted to fulfil the requirements for WP 4200, as described in the following section.

5.1 Growth chamber specifications

5.1.1 Hydroponics system

Experiments are carried out in a 16 m² walk-in growth chamber (4 m x 4 m) equipped with a recirculating NFT system (Fig. 55 and Fig. 56). Four cultivars of soybean have been selected for the bench tests. Three PP 60-cm high double gullies equipped with PE tubing and connections are used for each cultivar. A total of 12 double gullies are arranged in the chamber. 14 plants are grown per double trough (42 plants per cultivar in total). Each individual gully is 12 cm wide, 93 cm long and 5 cm high and is equipped with 3 sprinklers, to provide the nutrient solution. Seeds are placed in a small plastic basket in the gully holes (Fig. 57) in Perlite, keeping the moisture of the substrate constant.

Fertigation is performed with one separate nutrient solution reservoir (PP) per each double gully and each reservoir is equipped with its own submersible pump. Nutrient solution returns to the nutrient reservoir by gravity.

The nutrient solution is based on the standard Hoagland solution 1/2 strength (Hoagland and Arnon, 1950), modified by Wheeler et al. (2008), according to specific requirement of soybean. The starting nutrient solution has the following ion concentration:

7.5 mM N, 3.0 mM K, 0.5 mM P, 2.5 mM Ca, 1.0 mM Mg, 1.0 mM S, 60 µM Fe, 7.4 µM Mn, 0.96 µM Zn, 1.04 µM Cu, 7.13 µM B and 0.01 µM Mo (Wheeler et al., 2008).

The salt composition of the nutrient solution is shown in Tab. 19.

EC and pH are kept at 1.2 dS m⁻¹ and 5.8 (Wheeler et al., 2008), respectively. Both are controlled manually and adjusted daily by adding deionised water and/or fresh nutrient solution and nitric acid or potassium hydroxide respectively in the storage tanks.

Water depletion is measured daily and the volume of the nutrient solution is kept constant.

TN 98.4.11	Preliminary trade-off for test plan and procedures
UGent	
This document is confidential property of the MELiSSA partners and shall not be used, duplicated, modified or transmitted without their authorization	
Memorandum of Understanding 19071/05/NL/CP	

Tab. 19 Salt composition of the nutrient solution (mg per litre of nutrient solution).

Calcium nitrate	545,00
Potassium nitrate	200,00
Iron chelate (Fe-EDTA, Fe EDDHA)	48,20
Magnesium sulphate	135,00
Monopotassium phosphate	68,14
Potassium sulphate	60,00
Boric acid	4,40
Copper sulphate	0,235
Zinc sulphate	2,643
Manganese sulphate	1,437
Ammonium molybdate	0,183

5.1.2 Environment control

Experiments are carried out under controlled environmental conditions (light intensity, temperature, relative humidity, and photoperiod (ON/OFF)).

Light is provided by 9 High Pressure Sodium (HPS) lamps (LU600/T GE Lucalox® T15 - 600 W, manufactured by GELighting) which are placed 20 cm from the ceiling in three lines (3 lamps per line). The light spectrum of lamp emission is shown in Fig. 58.

The growth chamber walls and floor are coated with a reflective Mylar film in order to optimize the light distribution. Lamps are separated from the growing environment by a pane of tempered glass designed to prevent convective heat transport into the room. The lamp inter-space is cooled by 4 ventilators.

Temperature and humidity control is performed by an air conditioning system (McQuay Intl., M5CM 040 ER - three-phase; 12 kW). To decrease relative humidity (RH), the system is controlled by a programmable hygrostat connected to a RH probe.

A fogging system is used for cooling and humidification. The system is equipped with a high pressure pump (70 bar) equipped with a safety valve. To increase RH over a certain threshold, the fogging system is switched on by a second programmable hygrostat connected to a second RH probe. Fresh water is sprinkled by 12 sprinklers placed on the top of the lateral walls (3 sprinklers per wall).

Two small fans are placed at the top and at the bottom of one wall for periodic change of the internal air.

The layout of the climate control devices and the gullies is shown in Fig. 59. Measurements have been carried out to map the possible light, T and RH gradients in order to minimize any border effect at the crop level. Particularly, the extinction profile of light distribution at different distances from the lamps and the uniformity of temperature and RH have been studied according to the scheme in Fig. 60.

Results show that the light distribution profile reflects the distance from the single lamp and the relative position to more lamps. However, the values of light intensity found in the vertical space that are really occupied by the canopy (height from 0 to 80 cm from the gully) are

TN 98.4.11	Preliminary trade-off for test plan and procedures
UGent	
This document is confidential property of the MELiSSA partners and shall not be used, duplicated, modified or transmitted without their authorization	
Memorandum of Understanding 19071/05/NL/CP	

acceptable for crop growth and development. The plant canopy is anticipated to be limited to 80cm, hence the PPFD values of Tab. 20 are considered homogeneous.

A virtual scheme of the spatial light distribution has been simulated on the basis of the measured data (Fig. 61).

Temperature within the vertical and the horizontal planes ranged between the interval 25.4 - 26.5 °C and RH from 67.1 to 73.3%, with no relevant gradient among the measurement positions (Tab. 21 and Tab. 22).

Temperature gradients in the chamber are limited to 0.4°C. 5 points at gully height (60 cm from the floor) at different distances from the air conditioning system were measured. Each measurement was performed 3 times. In Fig. 62 the average values are given.

5.1.3 *Experimental set up*

Four cultivars of soybean have been selected for the bench tests according to the defined selection criteria: ‘PR91M10’, ‘Clara’, ‘Regir’, ‘Atlantic’. Selected cultivars are all classified as early maturing and photoperiod independent.

Plants are grown from certified seed sources. Germination tests are performed before starting the bench test in order to measure the germination percentage and the Mean Germination Time ($MGT = \sum Dn / \sum n$; where n is the number of seeds germinated per day, D the number of days from the beginning of the test).

Germination is carried out at 20 °C in the dark (Martínez-Villaluenga et al., 2006; Wheeler et al., 2004). A pre-soak treatment in DI water is performed in preliminary trials (Mackowiak et al., 1999) in order to evaluate the effect of the seed imbibition on the germination performance (time and percentage).

Seeds in the small plastics baskets are covered with white acrylic covers for 4 days after planting to shade seedlings and maintain high humidity. Three seeds are used for each hole and are reduced to one after seedling emergence (approximately 8 DAP). Plants are sealed in the gully holes by a two sided polyethylene film, with the black inside, to reduce the amount of light in the roots, and the white one outside to reflect light back into the developing canopy.

The experiment is set at the growing conditions listed below, considering the optimum values for soybean.

A minimum PPFD of 600 $\mu\text{mol cm}^{-2}\text{s}^{-1}$ is obtained at the canopy level by regulating the height of the gullies, according to a day/night regime of 12/12 hours (Wheeler et al., 2008).

Temperature regime is established at 26/20 °C (light/dark) and relative humidity (RH) is kept within the optimum range of 65-75% (Wheeler et al., 2008).

The experiment is carried out under ambient CO₂ and O₂ concentration and atmospheric pressure.

Light intensity, temperature and relative humidity are recorded hourly by using a Delta OHM DO 9847K data logger. Average and integral values are calculated daily.

TN 98.4.11	Preliminary trade-off for test plan and procedures
UGent	
This document is confidential property of the MELiSSA partners and shall not be used, duplicated, modified or transmitted without their authorization	
Memorandum of Understanding 19071/05/NL/CP	



Fig. 55 Views of the double gully, the nutrient solution tank and the submerged pump.



Fig. 56 Air conditioning system in the growth chamber and reflective film on the floor.

TN 98.4.11	Preliminary trade-off for test plan and procedures
UGent	
<p>This document is confidential property of the MELiSSA partners and shall not be used, duplicated, modified or transmitted without their authorization</p> <p>Memorandum of Understanding 19071/05/NL/CP</p>	



Fig. 57 Plastic basket for seeds and plants holding in the NFT gullies.

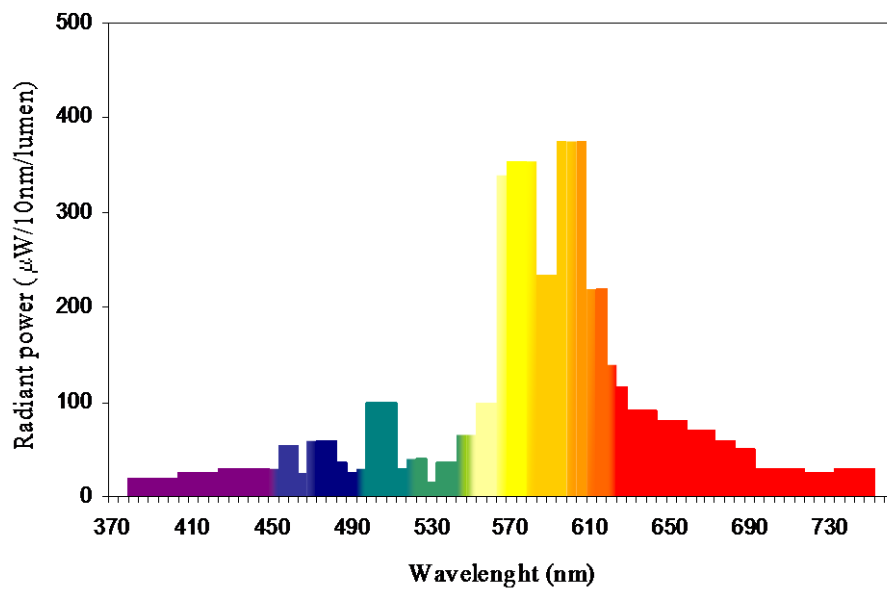

Fig. 58 The emission spectrum of HPS lamps LU600/T GE Lucalox® T15 - 600 W.

TN 98.4.11	Preliminary trade-off for test plan and procedures
UGent	
<p>This document is confidential property of the MELiSSA partners and shall not be used, duplicated, modified or transmitted without their authorization</p> <p>Memorandum of Understanding 19071/05/NL/CP</p>	

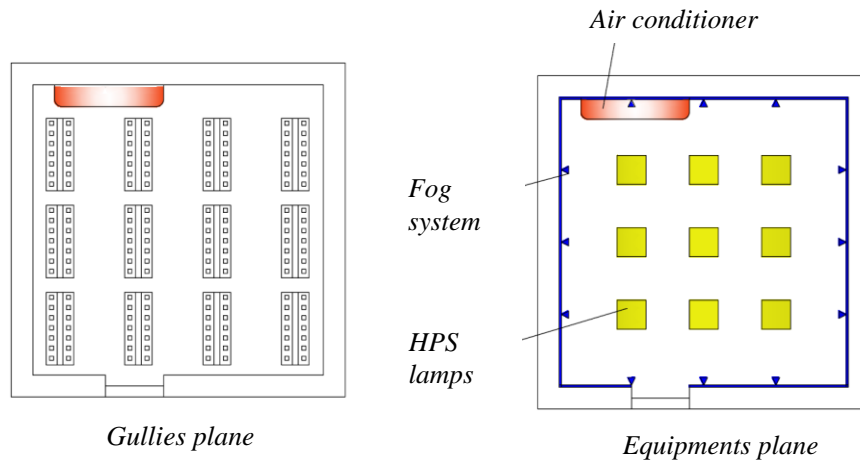

Fig. 59 Layout of the gullies and the climate control devices.

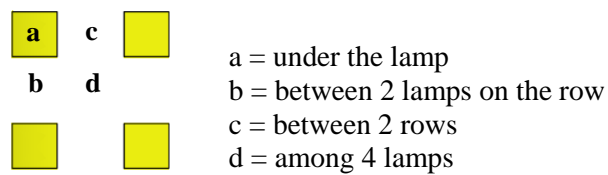

Fig. 60 Position of the measurements in relation to the lamps.

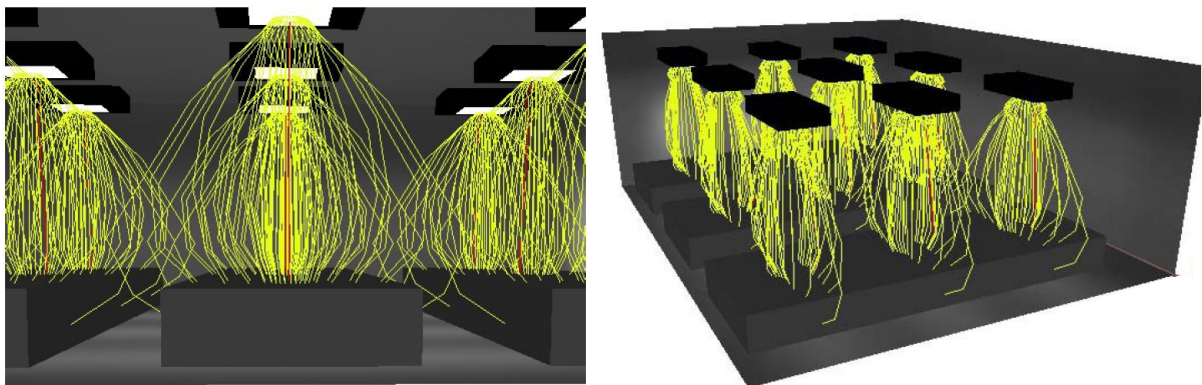

Fig. 61 Virtual spatial light distribution in the growth chamber.

TN 98.4.11	Preliminary trade-off for test plan and procedures
UGent	
This document is confidential property of the MELiSSA partners and shall not be used, duplicated, modified or transmitted without their authorization Memorandum of Understanding 19071/05/NL/CP	

Tab. 20 Vertical and horizontal light distribution ($\mu\text{mol}/\text{m}^2\text{s}$ average of 5 replicates).

Height from the gully (Distance from the lamp)	a	b	c	d
120 (40)	1452	1522	383	586
80 (80)	840	800	785	791
40 (120)	643	742	660	750
0 (160)	574	601	635	636

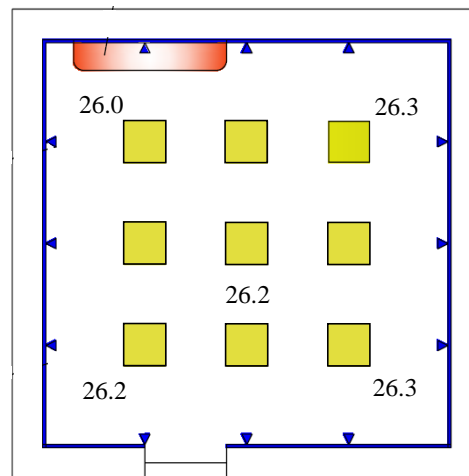

Fig. 62 Temperature at the height of the gullies

Tab. 21 Vertical and horizontal temperature distribution ($^{\circ}\text{C}$; average of 5 replicates)

Height from the gully (Distance from the lamp)	a	b	c	d
120 (40)	25.6	26.2	25.7	26.1
80 (80)	25.7	25.4	25.8	25.7
40 (120)	25.8	26.2	25.9	26.1
0 (160)	25.7	25.5	25.8	26.5

Tab. 22 Vertical and horizontal RH distribution (%; average of 5 replicates).

Height from the gully (Distance from the lamp)	a	b	c	d
120 (40)	73.3	69.5	72.0	68.8
80 (80)	72.9	67.1	73.1	67.6
40 (120)	71.4	72.3	70.9	67.1
0 (160)	71.0	67.2	70.9	70.2

The 4 cultivars are randomly distributed over the 12 independent hydroponic units as seen in Fig. 63.

TN 98.4.11	Preliminary trade-off for test plan and procedures
UGent	
This document is confidential property of the MELiSSA partners and shall not be used, duplicated, modified or transmitted without their authorization	
Memorandum of Understanding 19071/05/NL/CP	

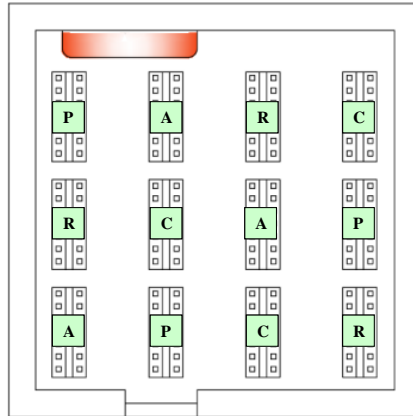

Fig. 63 Random distribution of the soybean cultivars in the growth chamber

5.2 Test plan

Given the typical crop cycle duration and on the basis of the previous research experiences of UNapoli, 15 weeks have been estimated as the expected time to complete a whole growing cycle. A summary of the measurements schedule is shown in Fig. 64.

5.2.1 Sampling and Measurements

5.2.1.1 Plant growth and physiology

The plant growth and development is measured at 7-day intervals. Growth analysis is based on non-destructive measurements of plant height, number of lateral shoots and leaves. Plant LA is estimated by measuring leaf length and width, taking into account the specific leaf shape. Measurements are carried out on 6 plants per each cultivar (3 plants per gully).

Leaf gas exchanges (stomatal conductance, net photosynthesis and transpiration rate) are monitored every two weeks by using a portable photosynthesis system (WALZ HCM 1000; measuring principle: variation of CO₂ concentration on the basis of the specific absorbance of these molecules in the Infra Red waveband; measuring unit: μmol CO₂ m⁻² s⁻¹). Gas exchange is studied under the experiment environmental conditions and as a function of light intensity. Light saturation curves are performed at increasing levels of light intensity (PPFD 0, 50, 100, 250, 1000, 1500 e 2000 μmol m⁻² s⁻¹), by using a built-in halogen lamp, keeping constant leaf chamber conditions (Walz, 1996). Whole plant gas exchange is estimated by up scaling the leaf net photosynthesis to the estimated plant LA.

On the leaf samples used for the gas exchange measurements, the water status of plant tissues is determined periodically by additional measurements of stomatal conductance with a porometer (Leaf Porometer AP4, Delta T Devices, Cambridge; measuring principle: diffusion conductance rate on the basis of the humidification in the cuvette; measuring unit: stomatal conductance in mmol m⁻² s⁻¹; measuring range 5.0÷1200 mmol m⁻² s⁻¹; accuracy ±10%) and by determining the leaf water potential, with a psychrometer working on the dew point method

TN 98.4.11	Preliminary trade-off for test plan and procedures
UGent	
This document is confidential property of the MELiSSA partners and shall not be used, duplicated, modified or transmitted without their authorization	
Memorandum of Understanding 19071/05/NL/CP	

(PotentiaMeter WP4 Decagon Device; measuring principle: chilled mirror dew point; measuring unit: negative pressure units MPa). A 12 cm² leaf sample is required for LWP (WP4 Dewpoint PotentiaMeter Operator's Manual, 2000; measuring range 0÷-40 MPa; accuracy ±0.1 MPa).

The chlorophyll content is estimated on the basis of leaf greenness, measured by using a Chlorophyll Meter Konica-Minolta (SPAD 502; measuring principle: optical density difference at two wavelengths; measuring unit: SPAD units; measuring range 0÷199). For higher accuracy it is then measured directly by extraction in acetone and spectrophotometric determination (Jeffrey and Humphrey, 1975; measuring principle: molecule optical properties (specific light absorbance); measuring unit: µg cm⁻² leaf area; µg mg⁻¹ leaf dry weight). A 2 cm² leaf sample is required for the extraction.

All physiological measurements are performed on two fully expanded leaves per plant on three plants per cultivar.

In addition to the values of air CO₂ concentration determined during the gas exchange measurements, CO₂ is measured monthly during a full light and dark period.

5.2.1.2 Water consumption and nutrient uptake

Crop water consumption is calculated on the basis of the water balance of each double gully, by measuring the volume of the supplied water and nutrient solution, subtracting the amount of water evaporated from the gully system (minimized by plastic covering, determined in the absence of plants). The water use efficiency (WUE), as g of biomass per kg of water consumed, is calculated at the end of the growing cycle.

Concentration of the main macronutrients (NO₃⁻, PO₄³⁻, K⁺) in the recycling solution is measured weekly during the crop cycle, while more detailed analyses (NO₃⁻, PO₄³⁻, K⁺, Cl⁻, Ca²⁺, Mg²⁺, SO₄²⁻, B³⁺) are performed at the start (fresh solution), at the end of vegetative phase (approximately after 7 weeks, nutrient solution exchange) and at the end (harvest) of the growing cycle. Samples are collected separately for the four cultivars and chemical analyses are performed with a spectrophotometer Hach DR 4000. Spectrophotometer measurements are performed on samples of nutrient solution diluted in deionised water, according to the protocols provided by the manufacturer (Hach, 1995).

The nitrate concentration in the recycling solution is also determined weekly using a portable reflectometer Nitracheck kit. Samples are read on test reactive strips (Merckoquant) and values are compared to those from the analytical procedure (measuring principle: colorimetric reading of reactive strips; measuring unit: mg l⁻¹ or ppm).

Plant tissue analyses are performed twice, at the full vegetative growth and at the harvest stage, on the different organs (roots, stems, leaves). Organic nitrogen is determined by the Kjeldahl Method (Kjeldahl, 1883). The main nutrient concentration (N, P, K, Ca, Mg, S, Fe, Cl) is determined on leaf extract, with a spectrophotometer Hach DR 2000. Analyses are carried out separately, on the DM of 6 plants per cultivar (3 plants x double gully) samples per organ per each cultivar, in order to investigate the specific nutrient requirements. DM is measured after oven-drying at 60°C and until a constant weight is achieved. Spectrophotometer readings are determined on water extracts according to the protocols provided by the manufacturer (Hach, 1995). Total uptake and nutrient partitioning is calculated for each element and cultivar.

TN 98.4.11	Preliminary trade-off for test plan and procedures
UGent	
This document is confidential property of the MELiSSA partners and shall not be used, duplicated, modified or transmitted without their authorization	
Memorandum of Understanding 19071/05/NL/CP	

5.2.1.3 Yield performance

Edible/non edible biomass produced per surface, volume and time unit are measured for each cultivar. Fresh weight, dry weight, % of DM and DM partitioning are measured separately for the different organs. Balances with $\pm 0.001\text{g}$ sensitivity are used for fresh and dry weight measurements. On non-edible biomass, cellulose and lignin are determined following MELiSSA procedures. Plant LA is measured at the harvest using a leaf area meter (LI-COR 3000, LI-COR, Lincoln, NE, USA). The number and the weight of pods and seeds are measured at the harvest for the different cultivars compared. The volume of the drained solution (water waste) and the weight and volume of non edible plant tissues (plant waste) are measured after the harvest.

5.2.1.4 Growth and Efficiency Indexes

The raw data of plant growth is collected in order to follow the time course of the main parameters (plant height, number of lateral shoots and leaves). At the end of the growing cycle, the more suitable growth indexes among the following will be calculated on the basis of the collected data:

- CGR (Crop Growth Rate) = $1/A * (M2-M1)/(T2- T1)$, where A = leaf area, T1 = start time, T2 = final time, M1 = plant biomass at T1 (DM), M2 = plant biomass at T2 (DM);
- NAR (Net Assimilation Rate) = $1/(L2-L1)* (M2-M1)/(T2-T1)$, where T1 = start time, T2 = final time, M1 = plant biomass (DM) at T1, M2 = plant biomass (DM) at T2, L1= plant leaf area at T1, L2 = plant leaf area at T2;
- HI (Harvest Index) will be calculated at the harvest by dividing the edible DM by the total DM in order to compare the yield performances of the four cultivars;
- WUE (Water Use Efficiency) expressed as g of edible DM per liter of nutrient solution, will be calculated by dividing the edible DM production by the cumulative water consumption;
- RUE (Radiation Use Efficiency), expressed as g of edible DM per mol of PAR, will be calculated by dividing the edible DM production by the light integral measured at the harvest at the canopy level.

5.2.1.5 Cultivation system requirements and critical points identification

The experiment is monitored on a daily basis by dedicated personnel. No unattended periods longer than the night time occur during the tests. Climatic data logger work continuously during the experimental period in order to detect any atypical value in environmental parameters.

Based on the sterilisation protocol of seeds (seed certification, seed sterilization), many of the potential risks related to plant pathogens are reduced. In addition, safety procedures are used in order to minimize any other risk (preliminary cleaning of all the devices, use of lab coats and gloves for personnel).

TN 98.4.11	Preliminary trade-off for test plan and procedures
UGent	
<p style="text-align: center;">This document is confidential property of the MELiSSA partners and shall not be used, duplicated, modified or transmitted without their authorization Memorandum of Understanding 19071/05/NL/CP</p>	

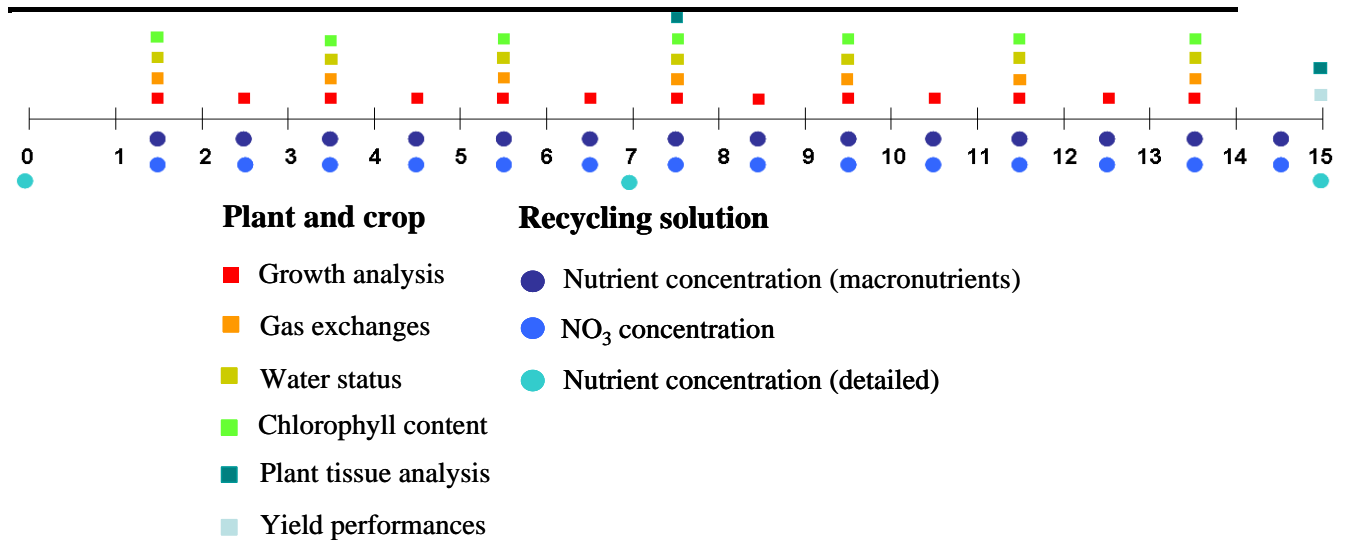

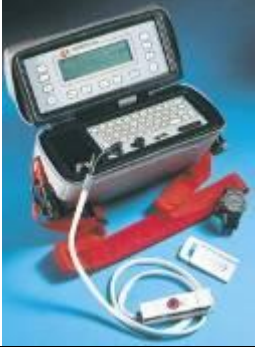







Fig. 64 Schedule of the measurements on plant and crop and on nutrient solution.

5.2.2 References of the measuring devices

<p><i>Portable photosynthesis system (WALZ HCM 1000)</i> <i>Non destructive measurement</i></p>	<p><i>Leaf Porometer (AP4 Delta T Devices)</i> <i>Non destructive measurement</i></p>
	
<p><i>Psychrometer (PotentiaMeter WP4 Decagon Device)</i> <i>Destructive measurement</i></p>	<p><i>Chlorophyll Meter (Konica-Minolta SPAD 502)</i> <i>Non destructive measurement</i></p>
	
<p><i>Leaf Area Meter (Li-Cor 3100, Li-Cor, Lincoln, NE, USA)</i> <i>Destructive measurement</i></p>	<p><i>Spectrophotometer (HACH DR 4000)</i> <i>Destructive measurement</i></p>

<p>TN 98.4.11 UGent</p>	<p>Preliminary trade-off for test plan and procedures</p>
-----------------------------	---

This document is confidential property of the MELiSSA partners and shall not be used, duplicated, modified or transmitted without their authorization
Memorandum of Understanding 19071/05/NL/CP

	
<p><i>Portable Reflectometer (Nitracheck kit)</i></p>	<p><i>Analytic Balance (ORMA mod. BC)</i></p>
	

5.2.3 References

- Hach, 1995. HACH DR 4000-U Spectrophotometer Handbook. Hach Company, Loveland, Colorado (USA).
- Hach, 1997. HACH DR 2000 Spectrophotometer Handbook. Hach Company, Loveland, Colorado (USA).
- Hoagland D. R. and Arnon D. I., 1950. The water-culture method for growing plants without soil. College of Agriculture, Univ. of California, Berkeley, California, USA, Circular 347, 32 pp.
- Jeffrey. S. W., Humphrey. G. F., 1975. New spectrophotometric equations for determining chlorophylls a, b, c1 and c2 in higher plants, algae and natural phytoplankton. *Biochem. Physiol. Pflanz.* 167: 191-194.
- Kjeldahl J., 1883. A new method for the determination of nitrogen in organic matter. *Z. Anal. Chem.* 22: 366.
- Mackowiak C. L., Stutte G. W., Wheeler R.M., Ruffe L. M., Yorio N. C., 1999. Tomato and soybean production on a shared recirculating hydroponic system. *Proc. Int. Sym. Growing Media and Hydroponics*. ED. A.P. Papadopoulos. *Acta Hort.* 481, ISHS: 259-266.
- Martínez-Villaluenga C., Yu-Haey K., Lambein F., Frías J., Vidal-Valverde C., 2006. Kinetics of free protein amino acids, free non-protein amino acids and trigonelline in soybean (*Glycine max* L.) and lupin (*Lupinus angustifolius* L.) sprouts. *Eur Food Res Technol*, 224: 177-186.
- Prosky L., Asp N.F., Schweizer T.F., De Vries J.W., Furda I., 1998. Determination of insoluble and total dietary fiber in food and food products. *J.A.O.C.S.*, 71: 1017-1023.

TN 98.4.11	Preliminary trade-off for test plan and procedures
UGent	
<p>This document is confidential property of the MELiSSA partners and shall not be used, duplicated, modified or transmitted without their authorization</p> <p>Memorandum of Understanding 19071/05/NL/CP</p>	

-
- Strayer R.F., 1994. Dynamics of microorganism populations in recirculating nutrient solutions. *Adv. Space Res.*, 14: 357-366.
- Walz GmbH, 1996. Portable Photosynthesis System HCM-1000. Software version 1.01. Heinz Walz Ed. Eichenring 6 – D-91090 Effeltrich (Germany).
- Weeler R.M., Corey K.A., Volk G.M., Mackowiak, C.L., Yorio N.C., Sager J.C., 2004. Soybean canopy gas exchange rates: effects of lighting. *Eco-Engineering*, 16 (3): 209-214.
- Wheeler R.M., Mackowiak C.L., Stutte G.S., Yorio N.C., Ruffe L.M., Sager J.C., Prince R.P., Knott W.M., 2008. Crop productivities and radiation use efficiencies for bioregenerative life support. *Adv. Space Res.*, 41: 706-713.
- WP4 Dewpoint Potentiometer Operator's Manual, 2000. Decagon Devices Inc. 950 NE Nelson CT. Pullman, WA – USA.

5.3 Seed and product analysis

5.3.1 Dry mass

Dry mass is calculated as percentage difference between fresh weight and weight after desiccation in an oven set to 60°C.

5.3.2 Fat content

Fat content is determined gravimetrically using the Soxhlet method.

- 5 g of dry sample is placed inside a thimble made from thick filter paper, which is then
- The thimble is loaded into the main chamber of the Soxhlet extractor (Bicasa Mod. BE 53).
- Ethyl ether is used as the extraction solvent.
- Fat content is expressed as percentage on fresh weight or dry mass.

5.3.3 Protein content

Protein content is determined by Kjeldahl method (Kjeldahl, 1883 using a digester (DK20 Healding Digester, VELP SCIENTIFICA) and a distillation unit (UDK 140, VELP SCIENTIFICA).

Titration of released ammonia allows calculation of nitrogen percentage and protein content using a conversion factor of 5.70 for soybean proteins.

5.3.4 Fibre content

Total dietary fibre is determined using AOAC method 985.29.

1 g of defatted sample is melted in 40 ml Tris Buffer Mes 0.05 mM pH 8.2 inside a crucible.

TN 98.4.11	Preliminary trade-off for test plan and procedures
UGent	
This document is confidential property of the MELiSSA partners and shall not be used, duplicated, modified or transmitted without their authorization	
Memorandum of Understanding 19071/05/NL/CP	

The sample, with 50 μL α - amylase is heated held at 100°C for 35 min in order to obtain gelatinization, hydrolysis and depolymerisation of starch.

After cooling to 63°C, 100 μL protease is added and the solution is heated again at 100°C for 30 min in order to obtain melting and depolymerisation of protein. The reaction is stopped with 5 ml HCl and the pH is adjusted to 4.1/4.8.

200 μL amino- glucosidase is added and the solution is heated to 60°C for 30 min in order to obtain hydrolysis of starch fragments to glucose.

300 ml ethanol at 60 °C is added and the solution is left in the extraction for 1 h in order to precipitate soluble fibre and eliminate protein and glucose. The solution is filtered and the residual is washed 3 times with 25 ml 78% ethanol, 2 times with 10 ml 100% ethanol and 2 times with acetone.

The crucible with extracted fibres is put in stove at 103 °C for 12 hours and is then weighed: dry residual (R).

Then the crucible is put in a muffle furnace (505 °C) for 5 h and is then weighed. Based on that, the amount of ashes is calculated.

Total dietary fibre (TDF) is calculated as follows:

$$\text{TDF} = \{[\text{R} - (\text{p} + \text{A}) / 100 * \text{R}] - \text{W}\} / \text{M} * 100$$

where:

M = sample weight

R = dry mass of M

A = ashes of M

p = protein in R

W = white = WR-WP-WA

WR = dry mass in white

WA = ashes in white

WP = protein in white

5.3.5 Carbohydrate content

Total amount of carbohydrates are determined as difference from dry mass.

5.3.6 Phytic acid analysis

The method described by Ishiguro et al (2003) will be used.

In order to extract phytic acid from soybeans, 0.5 g of milled seeds are mixed in 10 ml of 0.5 M HCl and shaken for 1 h at room temperature, followed by centrifugation for 6 min at 18000 x g. The supernatant is then analysed as detailed below. For soymilk samples the extraction step is not necessary.

0.9 mL of sample is mixed with the same volume of 6% trichloroacetic acid (TCA) solution containing 20% sodium sulphate. The mixture is allowed to settle for 20 min at room temperature and centrifuged at 8000 x g for 3 min. The supernatant (1.0 ml) is mixed with a half volume (0.5 ml) of FeCl_3 solution (0.2 % Fe in 0.5 M HCl). The mixture is incubated in a

TN 98.4.11	Preliminary trade-off for test plan and procedures
UGent	
This document is confidential property of the MELiSSA partners and shall not be used, duplicated, modified or transmitted without their authorization	
Memorandum of Understanding 19071/05/NL/CP	

water bath at 97°C (Grant W14) for 90 min, cooled at room temperature and then centrifuged at 1000 x g for 6 min. The precipitate is dispersed into 1.0 ml of washing solution containing 0.6 % HCl and 2.5% Na₂SO₄ and then centrifuged at 1000 x g for 6 min. The precipitate is dissolved in 1.0 ml of 0.9 N HCl.

The iron content is measured by the o-phenanthroline method:

1 ml of 10% hydroxylamine is added to the mixture; after 5 min, 5 ml of 0.25 % o-phenanthroline

is added and the volume is adjusted to 50 ml. After 5 min the absorbance at 510 nm is read by the spectrometer UV/ VIS LAMBDA 10 Perkin Elmer.

Phytate reference solution for a standard calibration is prepared by dissolving phytic acid calcium salt (Sigma Aldrich) in HCl 0.1 N.

The result of the spectrophotometric analysis (absorbance value) is converted in phytic acid concentration. Calibration range is 0.500÷0.063 ppm.

Accuracy of the method is estimated based on the mean percentage of error of the measured concentration (ConM) to the theoretical concentration (ConT) according to this equation:

$$\text{Bias (\%)} = [(\text{ConT}-\text{ConM})/\text{ConT}] \times 100$$

The accuracy was always well below the 10%

5.3.7 Isoflavones analysis

The method described by Otieno et al (2007) is used. The extraction of isoflavones from soymilk is carried out with a mixture 70% MeOH (1 g of dried and milled seeds in 30 ml and 0.5 g of frozen-dry soymilk in 25 ml of mixture) for 30 min at room temperature in an ultrasonic bath. The mixture is then centrifuged and the supernatant analyzed.

The first step of identification is performed by LC/MS/MS as it is currently the most sensitive and selective analytical method for rapid qualitative and quantitative analysis.

The isoflavones have been found to produce characteristic radical ions; product ion fragment reveal unique fragmentation pathways for each isoflavone compounds, so characteristic fragmentation of different isoflavones can be unequivocally identified and differentiated. Information about production ion for soy isoflavones are obtained from Otieno et al. (2007).

An HPLC apparatus equipped with two Micropumps Series 200 (Perkin Elmer, Shellton, CT, USA), an UV/VIS series 200 (Perkin Elmer, Shellton, CT, USA) detector set at 280 nm and a Prodigy ODS3 100 Å column (250 x 4.6 mm, particle size 5 µm) (Phenomenex, CA, USA) are used. The eluents are: A water 0.2% formic acid; B acetonitrile/methanol (60:40 v/v). The gradient program is as follows: 20-30% B (6 min), 30-40% B (10 min), 40-50% B (8 min), 50-90% B (8 min), 90-90% B (3 min), 90-20% B (3 min) at a constant flow of 0.2 mL/min. The LC flow is split and 0.8 mL/min is sent to the mass spectrometry. Injection volume is 20 µL. MS and MS/MS analyses were performed on an API 3000 triple quadrupole mass spectrometer (Applied Biosystems, Canada) equipped with a TurboIonSpray source working in the positive ion mode.

6 glucosides (daidzin, genistin, glycitin, acetyl-genistin, malonyl-daidzin, malonyl-genistin) and only one aglycone (genistein) were identified (Tab. 23).

TN 98.4.11	Preliminary trade-off for test plan and procedures
UGent	
This document is confidential property of the MELiSSA partners and shall not be used, duplicated, modified or transmitted without their authorization	
Memorandum of Understanding 19071/05/NL/CP	

Tab. 23 Characterization of isoflavones present in soybean and soymilk extracted

Compound	Precursor ion [M-H ⁺] (m/z)	Product ion
Genistein	271	243 215 187
Daidzin	417	199 255
Genistin	433	215 271
Glycitin	447	285
Acetyl-genistin	475	431 417
Malonyl-daidzin	503	417
Malonyl-genistin	519	433

In the second step of quantification, filtered extract (20 µL) is injected into an HPLC (Shimadzu LC 10, Shimadzu, Kyoto, Japan) with a photodiode array detector.

Instrumental characteristics are the following:

- Accuracy of flow rate setting ±2%
- Precision of flow rate ±03%
- Pressure setting accuracy ±10%
- Pressure indication accuracy ±2%.

Separation is achieved on a Phenomenex column (C18 prodigy 5µ ODS3 100A size 250x 4.60 nm). Elution is performed using water and formic acid 0.2% (A) and HPLC-grade acetonitrile/methanol (60:40 v/v) (B) as the mobile phases, on a gradient starting with 20% B in A to reach 30% B at 6 min, 40% B at 16 min, 50% B at 24 min, 90% B at 32 min, 90% B at 35 min, and 20% B at 38 min. The flow rate is 0.8 mL/min, and chromatograms are recorded at 280 nm.

Flavonoids are first identified and confirmed by an LC/MS/MS analysis and then quantified (LC with diode array UV/VIS detector) using, as external standard genistein and genistin for all glucosides.

Genistein stock solution is prepared by dissolving standard (Sigma Aldrich) in methanol while genistin stock solution is prepared by dissolving standard (Sigma Aldrich) in a mixture MetOH/H₂O 70/30.

Results of chromatographic analysis (see Fig. 65) expressed as peak area, are converted into concentrations. Calibration range is 1÷50 ppm for genistein and 15÷250 ppm for genistin.

Accuracy of the method is estimated based on the mean percentage of error of the measured concentration (ConM) to the theoretical concentration (ConT) according to this equation:

$$\text{Bias (\%)} = [(\text{ConT} - \text{ConM}) / \text{ConT}] \times 100$$

The accuracy is around 5%

TN 98.4.11	Preliminary trade-off for test plan and procedures
UGent	
This document is confidential property of the MELiSSA partners and shall not be used, duplicated, modified or transmitted without their authorization	
Memorandum of Understanding 19071/05/NL/CP	

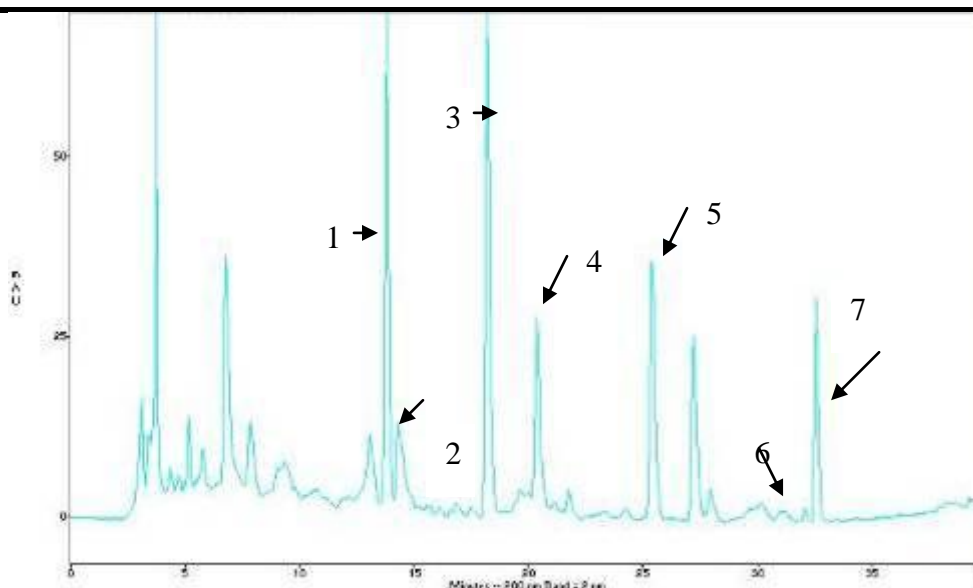

(1: daidzein – 2: glicitin – 3:genistin – 4:malonyl-daidzin 5: malonyl-genistin 6:acetyl-genistin 7:genistein)

Fig. 65 A typical liquid chromatograph.

5.3.8 Analysis plan

For every cultivar, 3 sampling * 2 repetitions are performed.

Summarising a dry mass and phytic acid analysis on fresh soybeans (or soymilk) is performed.

Furthermore, the dry mass and phytic acid analysis on dry mass is done.

Tab. 24 shows the amount of beans, we need for every analysis and in total.

Tab. 24 Amount of soybeans, we need for every analysis and in total.

Analysis	Amount (DW)	Amount (FW)
Dry mass		50 g fresh weight
Protein content	5 g of dry samples	
Fat content	1 g of dry samples	
Fiber content		1 gr (defatted sample)
Phytic acid content		0.5 g fresh weight
Isoflavavones profile	1 g of dry samples	
Tot. amount	7 g of dry mass	50.5 g fresh weight

TN 98.4.11	Preliminary trade-off for test plan and procedures
UGent	
This document is confidential property of the MELISSA partners and shall not be used, duplicated, modified or transmitted without their authorization	
Memorandum of Understanding 19071/05/NL/CP	

5.3.9 References of the measuring devices

All measurements are destructive.

Soxhlet extractor (BICASA mod BE 53)

DK 20 Heating Digester VELP SCIENTIFICA



UDK 140 Distillation Unit VELP SCIENTIFICA

Thermostat bath (GRANT W14)



Spectrometer UV/ VIS (LAMBDA 10 Perkin Elmer)

Micropumps Series 200 (Perkin Elmer)



API 3000 triple quadrupole mass spectrometer (Applied Biosystems)

HPLC (Shimadzu LC 10, Shimadzu)



TN 98.4.11
UGent

Preliminary trade-off for test plan and procedures

This document is confidential property of the MELiSSA partners and shall not be used, duplicated, modified or transmitted without their authorization
Memorandum of Understanding 19071/05/NL/CP

5.3.10 References

- Ishiguro T., Ono T., Nakasato K., Tsukamoto C. & Shimada S. (2003). Rapid measurement of pyhate in raw soymilk by Mid-infrared spectroscopy. *Biosci. Biotechnol. Biochem*, 64:752-757.
- Kjeldahl J., 1883. A new method for the determination of nitrogen in organic matter. *Z. Anal. Chem.* 22: 366.
- Otieno D., Rose H. & Shah N. (2007) Profiling and quantification of isoflavones in soymilk from soy protein isolate using extracted ion chromatography and positive ion fragmentation techniques. *Food chemistry*, 105, 1642-1651.
- Prosky L., Asp N.G., Schweizer T.F., De Vries J.W. & Furda I. (1998). Determination of insoluble, soluble and total dietary fiber in food and food products. *J. AOCS*, 71, 1071-1023.

TN 98.4.11	Preliminary trade-off for test plan and procedures
UGent	

This document is confidential property of the MELiSSA partners and shall not be used, duplicated, modified or transmitted without their authorization

Memorandum of Understanding 19071/05/NL/CP